



OPERATION MANUAL

ULS-25 LASER SYSTEM

Universal Laser Systems, Inc.

16008 North 81st Street

Scottsdale, AZ 85260

Phone: 602-483-1214

Fax: 602-483-5620

Volume I, Rev. 6

April 1995

TABLE OF CONTENTS

NOTICE.....	4
INTRODUCTION.....	5
SECTION 1 - SAFETY	
1.1 LASER SAFETY.....	6
1.2 SAFETY LABELS.....	7
1.3 THE SAFETY INTERLOCK SYSTEM	8
SECTION 2 - INSTALLATION	
2.1 UNPACKING AND ASSEMBLING THE SYSTEM	9
2.2 OPERATING ENVIRONMENT.....	11
2.3 EXHAUST SYSTEM REQUIREMENTS.....	12
2.4 COMPUTER RECOMMENDATIONS AND SETUP	13
2.5 LASER SYSTEM INSTALLATION.....	13
2.6 HOW TO INSTALL THE ULS WINDOWS PRINTER DRIVER	14
SECTION 3 - SOFTWARE SETUP AND OPERATION	
3.1 USING WINDOWS GRAPHICS SOFTWARE	16
3.2 THE ULS WINDOWS PRINTER DRIVER	21
3.3 USING DOS BASED PROGRAMS	26
SECTION 4 - LASER SYSTEM OPERATION	
4.1 GENERAL SYSTEM OVERVIEW.....	27
4.2 THE MAIN CONTROL PANEL	28
4.3 MOTION SYSTEM CONTROLS	38
4.4 LOADING AND FOCUSING THE LASER SYSTEM.....	39
4.5 RUNNING A SAMPLE.....	41
4.6 USING THE OPTIONAL ROTARY FIXTURE.....	42
4.7 THE RUBBER STAMP OPTION	48
4.8 START UP PARAMETERS FOR VARIOUS MATERIALS	51
SECTION 5 - BASIC MAINTENANCE	
5.1 GENERAL CLEANING OF THE SYSTEM.....	77
5.2 OPTICS CLEANING.....	72
SECTION 6 - APPENDICES	
APPENDIX A - WARRANTY.....	A
APPENDIX B - LASER SYSTEM SPECIFICATIONS	B
APPENDIX C - SERIAL PORT CABLE REQUIREMENTS	C
APPENDIX D - LASER.INI MODIFICATIONS	D

APPENDIX E - SOFTWARE ANOMALIESE

This publication and its contents are proprietary to Universal Laser Systems, Inc., and are intended solely for the contractual use of Universal Laser Systems, Inc. customers.

This publication and its contents may not be reproduced or distributed for any other purpose without the written permission of Universal Laser Systems, Inc.

**© UNIVERSAL LASER SYSTEMS INC., 1994
ALL RIGHTS RESERVED**

NOTICE

Universal Laser Systems, Inc. does not assume any liability arising out of the application or use of any products, circuits or software described herein. Neither does it convey a license under its patent rights nor the patent rights of others. Universal Laser Systems, Inc. further reserves the right to make any changes in any products described herein without notice. This document is subject to change without notice.

INTRODUCTION

The ULS-25 Laser System is designed to combine flexibility and full featured performance with simplicity and ease of use. Using advanced engineering and design, the ULS-25 offers finer control, higher precision, more versatility, better resolution, and overall greater quality than any other laser system in its class. It combines the performance of high speed engraving and cutting capabilities with the ease of a user friendly, specially designed, Windows printer driver interface. Actually, the ULS-25 is such a breakthrough in technology that it is more than just a laser system, it is a precision engraving and cutting device used as a tool for the imagination.

To begin with, we highly recommend that this entire manual be read before attempting to use the laser system. The manual includes important information about the safety, assembly, use, and maintenance of the laser system. **We cannot overemphasize the importance of reading the owner's manual completely.**

Where to get HELP:

If it is necessary to call for technical assistance, please call our technical support services at (602)483-1214. Please be prepared to answer our questions by following the procedures below, as this will allow us to provide assistance in a prompt and efficient manner:

- Take a moment to write down all of the pertinent information about the computer being used with the laser cutting and engraving system such as software, operating system and computer type.
- Try to recreate the problem and write down the circumstances in which the problem occurred. This will help our technical staff tremendously.
- If possible call from a phone that is close to the laser engraving system so that the system can be operated while talking with our technical support staff.

SECTION 1 - SAFETY

1.1 LASER SAFETY

This laser engraving system contains a sealed carbon dioxide laser produces intense and ***invisible*** laser radiation (at a wavelength of 10.6 microns in the infrared spectrum). The ULS laser engraving system is designed as a CLASS I device, meaning that the system is equipped with a protective housing and safety devices to completely contain the laser under normal use. Do not at any time attempt to modify or disassemble any part of the system and do not attempt to operate a system that has been modified or disassembled. Improper use of controls and adjustments or performance of procedures other than those specified in this manual may invalidate the Class I rating and result in exposure to the laser beam.

Please remember the following safety precautions when operating this laser cutting and engraving system:

1. Exposure to laser radiation may produce physical burns and can cause severe eye damage. Proper use and care of this system is very important to the safety of all people in the surrounding area.
2. Exposure to the laser beam may cause ignition of combustible materials so a properly maintained fire extinguisher should be kept on hand at all times.
3. Operation and care of this laser cutting and engraving system must be performed in accordance with this manual.
4. Dangerous voltages are present within the electronics and laser enclosures of this system. Although access to these areas is not necessary during normal use, if it becomes necessary to open one of these enclosures for service reasons please remember to **UNPLUG THE MACHINE FIRST**.
5. Never operate the laser system without properly exhausting the fumes generated by the cutting and engraving process.
6. Please contact ULS with any questions concerning laser safety before operating this system.

Note: ULS systems are specifically designed to comply with CDRH performance requirements under 21CFR 1040.10 and 1040.11. No guarantees of suitability or safety are provided for any use other than those specified by Universal Laser Systems, Inc.

1.2 SAFETY LABELS

According to CDRH standards, all interlocked and non-interlocked covers that allow access to a laser beam **must** have appropriate laser safety labels attached to them. These labels must be visible to personnel prior to the removal of the covers. Additional labels must be installed inside the machine and be visible if the covers are removed from the machine. Labels that provide the manufacturer's name, date of manufacture, description of product, model number, serial number and compliance statement must also be visible on the outside of the machine.

All CDRH required labels are properly affixed to the machine in the appropriate locations at the time of manufacture. These labels are not to be removed. If they become damaged or removed for any reason, please request additional labels from Universal Laser Systems (they will be provided free of charge). Below is a list of all the labels and their locations on the system.



Manufacturer's Label

Location: On the back of the machine in the lower left corner.

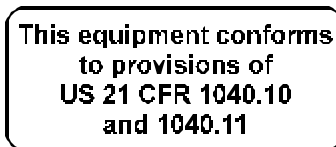

CDRH Compliance Label

Location: On the back of the machine below the Manufacturer's Label.

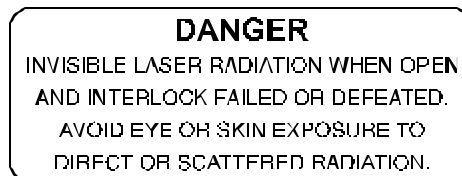

Warning Label for Interlocked Panels and Doors

Location: On the outside of the top door, on the inside of the top door (visible when door is open), on the outside of the front door, on the inside of the front door (visible when door is open) and next to the defeat interlock tool receptacle.



Exposure Warning Label

Location: Near the beam window inside the system where the laser beam enters the work area and next to the beam aperture inside the second mirror housing.

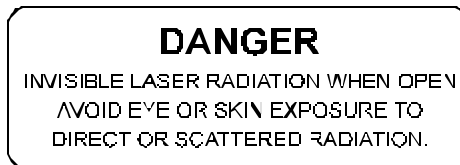

Warning Label for Non-interlocked Panels

Location: On the second mirror cover (visible when the electronics cover is open or removed) and on the floor of the second mirror housing (visible when the second mirror cover is removed).

1.3 THE SAFETY INTERLOCK SYSTEM

The laser cutting and engraving system incorporates a safety interlock circuit that automatically shuts off the power supplied to the laser whenever the front or top door is opened. This interlock system is connected in series with a switch and a red indicator light on the control panel of the system. The switch allows the power to the laser to be manually turned on and off. The red indicator light will light up when power is being supplied to the laser. If at any time the red indicator light remains on when the front or top door is open, immediately unplug the system and call Universal Laser Systems for service instructions.



WARNING:

Do not attempt to modify or defeat the safety interlock system for any reason as this could result in exposure to hazardous laser radiation.



WARNING:

When using the interlock defeat tool, wear appropriate laser safety goggles. Failure to wear appropriate goggles can result in severe eye damage.

SECTION 2 - INSTALLATION

2.1 UNPACKING AND ASSEMBLING THE SYSTEM

The laser engraving machine is shipped in one crate that contains the system, a cart with casters and various accessories. The following steps outline the unpacking and assembly of the system. Please follow these steps carefully.

IMPORTANT

Save the shipping crate. If the system must be returned for service, it will have to be packed in its original shipping crate.

1. Remove the top and four sides from the wooden shipping crate. Remember, after the laser engraving system is assembled, store the flattened crate in a dry place.
2. Remove the cart panel and accessories box from the crate. The cart panel is shipped between two pieces of foam in front of the laser engraving system and the accessories box is shipped behind the system underneath the enclosure with the four fans mounted on it.
3. Carefully remove the foam which protects the viewing window on the top of the system and remove the tape which holds the top door in place.
4. Remove the box containing the two cart legs. This box is shipped inside the laser engraving system. To remove the box, open the top lid of the system and raise the engraving table by turning the engraving table adjusting knob clockwise until the table is raised high enough to free the box underneath it. Then open the front door of the system and slide the box out through the front opening.
5. Open the accessories box and remove the four black casters and the bag of hardware. The hardware bag should contain the following:

- (8) 10-32 Allen head screws
- (8) #10 lock washers
- (4) 1/4-20 Allen head screws
- (4) 1/4 " ID flat washers
- (1) 5/32 inch Allen wrench
- (1) 3/16 inch Allen wrench

A 3/4 inch wrench provided in the accessories box is needed to complete the stand assembly.

6. Using the smaller Allen wrench, attach the two legs to the center panel with the eight 10-32 Allen head screws and #10 lock washers as shown in the figure below.

7. Attach the four black casters to the cart by threading the casters into the nuts that are welded onto the bottom of each leg. Tighten each caster in place with the 3/4 inch wrench. There are two locking and two non-locking casters provided. Make sure when attaching the casters that the locking casters are installed on the front of the cart. To identify the front of the cart look at the center panel. The finished side of the center panel should face forward (see figure below).

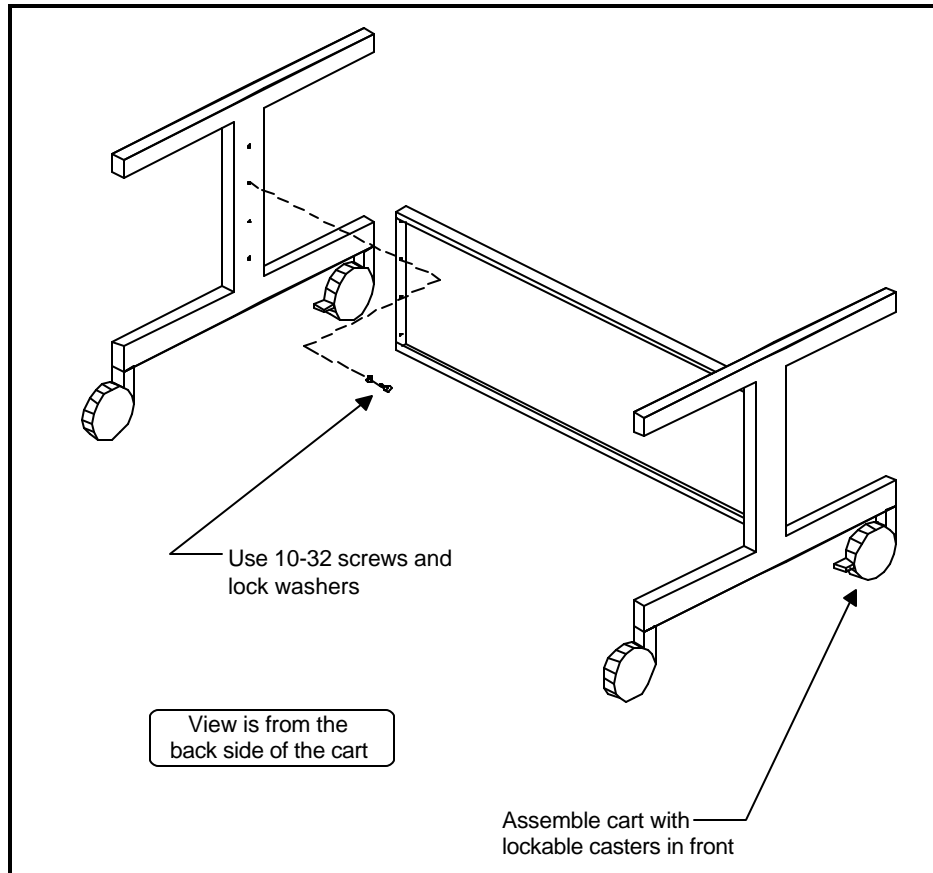

Cart Assembly

8. When the cart is assembled, position it so that the finished side of the center panel is facing forward.
9. Lift the laser engraving system from the crate and place it on the cart. This will require two people as the machine weighs approximately 170 lbs.
10. Using the larger Allen wrench, attach the system to the cart using the four 1/4-20 Allen head screws and flat washers. The screws pass through the cart legs and into the bottom of the system as shown in the drawing below.

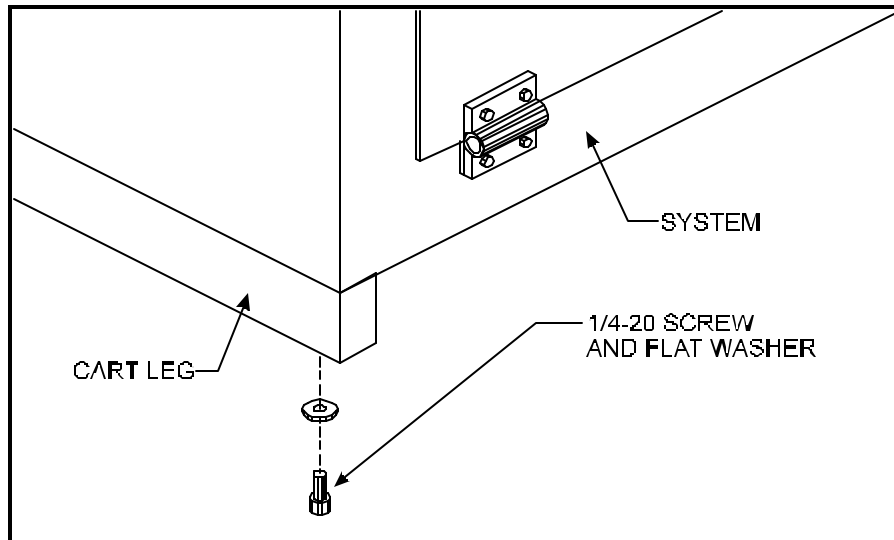

Attaching Cart to Laser System

2.2 OPERATING ENVIRONMENT

Before the system is installed, choose a suitable location. Follow the guidelines below:

- Avoid places where the system may be exposed to **high temperatures, dust,** or **high humidity** (humidity exceeding 70% or where the temperature is near the dewpoint). The laser system should be installed in an office type environment.
- Avoid places where the system may be exposed to high levels of vibration or electrical noise. We recommend using a high quality surge protector (15 Amp capability) to protect the laser engraving system's electronics.
- Avoid small enclosed areas where ventilation is poor.
- Choose a place where the ambient operating temperature will remain between 60 and 75 degrees Fahrenheit.
- Choose a place which provides a short and direct path to the exhaust duct work (not provided).
- If planning to connect the laser engraving system to a computer through the parallel port, choose a location where the computer can be placed within 10 feet of the machine since this is the recommended maximum distance for a parallel cable.

2.3 EXHAUST SYSTEM REQUIREMENTS

To properly exhaust fumes and smoke from the laser engraving system during operation, it is necessary to provide an exhaust unit moving a minimum of 235 CFM at 6 inches of static pressure. Many industrial supply companies carry blowers that should meet these requirements.

THROUGH OUR RESEARCH WE HAVE ESTABLISHED GUIDELINES ON THE PROPER CFM RATINGS REQUIRED FOR THE EXHAUST SYSTEM. THESE RATINGS ARE BASED ON THE MEASURED DISTANCE BETWEEN THE EXHAUST OUTLET ON THE LASER SYSTEM AND THE INLET OF THE EXHAUST BLOWER. WE HAVE FOUND A SUITABLE SUPPLIER FOR THIS TYPE OF EQUIPMENT IF YOU CHOOSE NOT TO USE THIS SUPPLIER, PLEASE ENSURE THAT THE BLOWER THAT YOU PURCHASE MEETS OR EXCEEDS THE FOLLOWING SPECIFICATIONS.

DISTANCE BETWEEN BLOWER AND LASER	CFM RATING AT 6 INCHES STATIC PRESSURE
UP TO 7 FEET	235 @ 6 INCHES STATIC PRESSURE
8 - 14 FEET	410 @ 6 INCHES STATIC PRESSURE
15 - 22 FEET	535 @ 6 INCHES STATIC PRESSURE
23 - 30 FEET	625 @ 6 INCHES STATIC PRESSURE

The blower must be mounted on the outside of the building either on the roof or on a cement pad next to the building. Rigid duct work should be used between the blower unit and the laser system. The exhaust tubing should be smooth walled and have as few bends as possible. Use duct work with a diameter that matches the blower unit and reduce the duct work to four inches just before the point where it attaches to the laser system. Also consider installing a gate to control air flow and to close off the exhaust from the outside environment when the laser is not in use. This is especially useful in colder climates where it is not good to have cold air coming into the laser from the outside. Do not connect the rigid duct work directly to the laser system. Use a short piece of industrial grade, wire reinforced rubber tubing to connect the end of the gate, or tubing, to the laser system. This will provide mobility and will dampen blower vibrations. Do not use a very long piece because it's spiral construction reduces air flow. Install a hose clamp on both ends of the hose to prevent leaks and to prevent the hose from slipping off.

Having the blower wired to a wall switch in the same room will make it easy to turn it off and on.



WARNING

Do not attempt to operate the laser engraving system without a properly installed and operating exhaust system. Some materials when cut or engraved can produce fumes that are hazardous in concentrated amounts.

We recommend installation of the exhaust system by a licensed contractor to meet safety and local code requirements. Please contact a local air quality control specialist. Again, if there are any questions, please contact our technical support.

TYPICAL ROOF MOUNT INSTALLATION

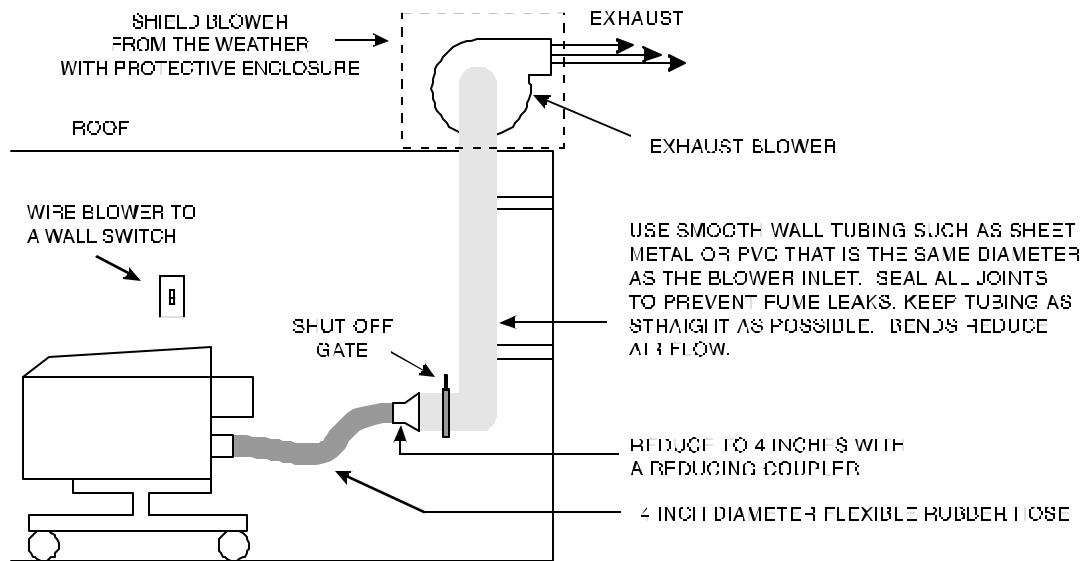

TYPICAL OUTSIDE MOUNT INSTALLATION

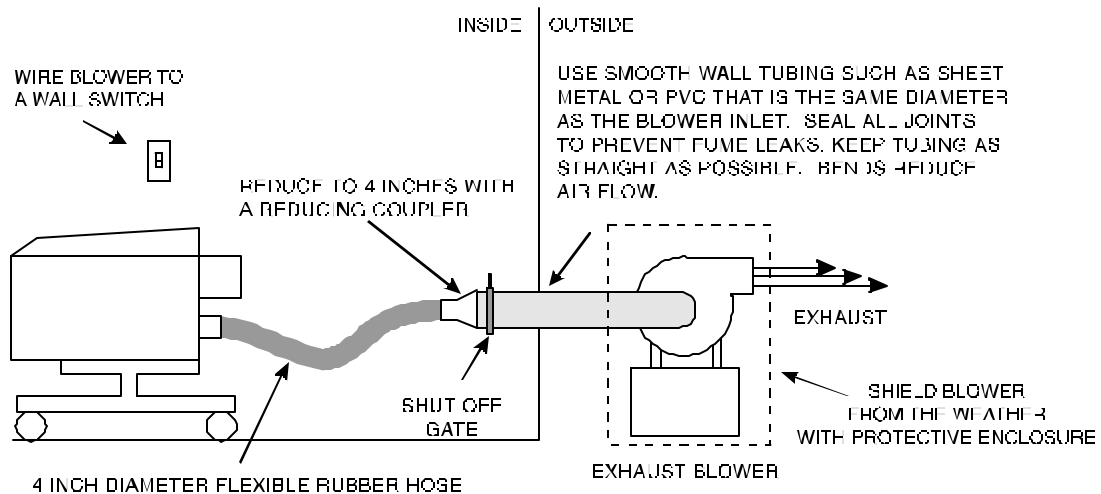

Sample Exhaust System Layouts

2.4 COMPUTER RECOMMENDATIONS AND SETUP

The following computer configuration is the **minimum** requirement necessary to operate in the Windows environment. Using a computer with more speed, memory, and storage capacity will enable the graphic images to be produced faster. A faster computer will perform calculations quicker and will shorten download time to the laser system. Remember, the following is the **minimum** requirement:

- 386 or higher PC compatible computer
- 4 MB of RAM
- 100 MB hard drive
- One floppy disk drive
- Color VGA monitor
- Mouse
- Microsoft Windows version 3.1
- Windows compatible graphics program

The same configuration can be used for CAD systems except Windows 3.1 and a Windows graphics program would not be necessary.

2.5 LASER SYSTEM INSTALLATION



CAUTION: Please make the following connections in the exact order described otherwise static electricity can damage the computer and/or the laser system's electronics.

1. Connect one end of the AC power cord into the receptacle on the right side of the laser system next to the on/off switch. Then connect the other end of the power cord to a 110 volt 60 Hz AC outlet through a good quality surge suppresser. Do the same for the computer system.
2. Make sure both the computer and laser engraving system are plugged in and turned **OFF**, then connect the laser engraving system to the computer using either a serial or parallel connection.. We recommend the use of a Parallel port connection because it normally provides the best performance. Refer to the following diagram.

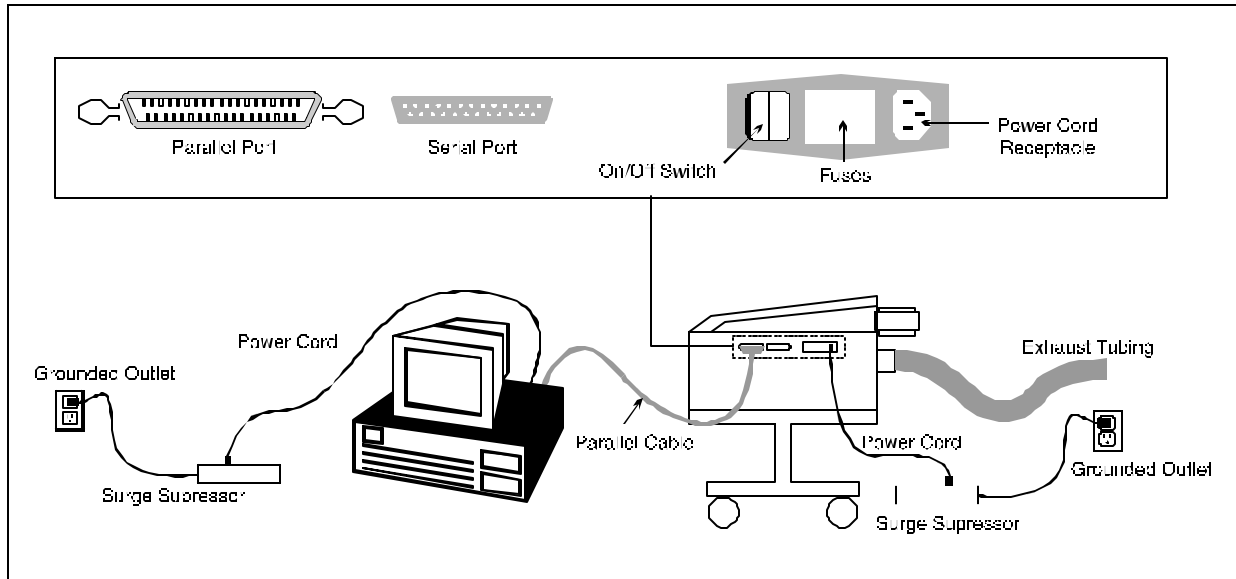

Cabling Connections

2.6 HOW TO INSTALL THE ULS WINDOWS PRINTER DRIVER

Installation of the ULS Windows Driver will allow Microsoft Windows version 3.1 to interface with the laser engraving system. This driver is installed the same way as most other Windows printer drivers, and a simple step-by-step installation procedure is outlined below. Complete understanding of how Microsoft Windows works is essential to the operation of the laser system. Please consult the Windows owner's manual on its installation, use, and operation before continuing.

Installation Procedure for the ULS Windows Driver:

1. Start Microsoft Windows, open the Main group in the Program Manager and choose the Control Panel icon. The Control Panel window should open up.
2. Choose the Printers icon from inside the Control Panel window. The printers dialog box should appear.
3. Press the Add button. The dialog box should expand to include a list of printer drivers as shown in the figure below.

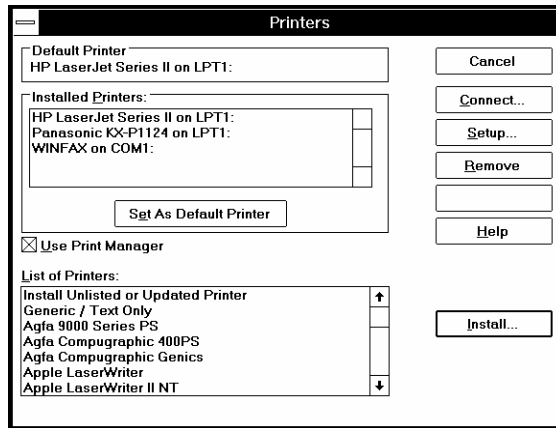

Printers Dialogue Box

4. Select "Install Unlisted or Updated Printer" and press the Install button. The Install Driver dialogue box should appear as in the figure below asking for the location of the new driver.

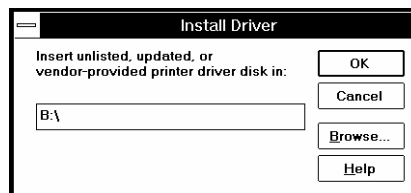

Add Unlisted Printers Dialog Box

5. Insert the floppy disk containing the Universal Laser Systems Windows Driver into the appropriate disk drive and type the letter of that drive in the Install Driver box.
6. Press the OK button. A new dialogue box called "Add Unlisted or Updated Printer" should appear. Choose the appropriate laser system from the list and press the OK button. The driver should now install itself and the laser system should appear in the "Installed Printer" dialog box.
7. Highlight the laser system and click on "Connect". Select the port the laser system is attached to. **NOTE:** A check box named "Fast Printing Direct to Port" located on the bottom of the dialog box should **NOT** be checked, otherwise file transmission errors can occur. Select OK.
8. Now you **MUST** click on SETUP to initiate the installation of the driver. The driver settings screen will now appear. Select OK in the lower right hand corner.
9. Setting the laser system as the default printer and using Print Manager are of personal preference. At this point, exit the Printers dialogue box and the Control Panel window. Printer driver installation is now complete. Store the driver disk in a safe place.

SECTION 3 - SOFTWARE SETUP AND OPERATION

3.1 USING WINDOWS GRAPHICS SOFTWARE

Page Setup

To properly generate and position artwork, most graphics software will permit the customization of the page size and orientation. Set the page orientation, in the graphics software to Landscape, and the page size to a horizontal length of 17 inches and vertical length of 11.5 inches. The ULS driver's orientation and page size **MUST** then be set to match these specifications, otherwise the artwork may not print correctly. When setting page orientation and driver orientation to Landscape mode, the laser system will operate in the horizontal direction, left to right. If page orientation and driver orientation is set to Portrait mode, the laser system will operate in the vertical direction, forwards and backwards. The laser system is designed to operate best in the Landscape mode and this orientation is highly recommended. The page size may also be reduced to match the size of the engraving material, but remember to adjust the page size in the ULS Windows printer driver to correspond to the graphics software's page size. Note that in production situations it is often more efficient to leave the page size at its maximum of 17 x 11.5 inches and engrave or cut more than one object at a time. This is accomplished by duplicating the image on screen as many times as necessary to fill up the entire page.

Ruler Setup

Usually the graphics software will provide on-screen rulers which can be configured to match the rulers in the laser system. Using rulers in the software and matching them with the ones provided in the laser system gives the ability to correctly align the graphic on the screen with the material in the laser system. The laser system's origin is fixed in the upper left corner of the engraving area and cannot be altered. It is necessary to change the ruler position on screen to match the laser system with the origin (0,0) in the upper left corner.

It is also possible to use a page size smaller than the maximum engraving area. For example, if an 8 x 10 inch page size is desired, set this page size in the graphics software as well as the ULS Windows printer driver. The laser system will automatically move the engraving area to the origin so place the 8 x 10 inch object all the way up into the left hand corner against the rulers in the laser system.

Power Control Through Color Selection

The laser system allows the use of 8 different colors to access 8 different power settings when cutting and engraving. This feature is controlled by the ULS Windows printer driver if using Microsoft Windows. When using this power change feature with the ULS Windows printer

driver, the colors that are used **MUST** exactly match the colors listed in the driver. The colors are black, red, green, yellow, blue, magenta, cyan, and orange. Some programs will provide these basic colors pre-defined and other programs may require the creation of each of the colors by defining them in CMYK percentages. If the eight driver colors are not automatically provided in the software, use the chart below to create the eight driver colors by specifying the appropriate CMYK values:

COLOR	CYAN	MAGENTA	YELLOW	BLACK
BLACK	0 %	0 %	0 %	100 %
RED	0 %	100 %	100 %	0 %
GREEN	100 %	0 %	100 %	0 %
YELLOW	0 %	0 %	100 %	0 %
BLUE	100 %	100 %	0 %	0 %
MAGENTA	0 %	100 %	0 %	0 %
CYAN	100 %	0 %	0 %	0 %
ORANGE	0 %	60 %	100 %	0 %

If using a color other than the exact colors listed above, the driver will attempt to match it to a color in the driver that it most closely resembles. The driver will then use that color's power setting and apply a halftone pattern to represent the original color's shade. For example, if using a color like pink to fill a rectangle, the driver takes a reading of the percentage of different colors used to create that color and will use the power setting assigned to one of the eight colors of the driver that it most closely resembles. It might be expected that the driver will use the power setting assigned to the color red but instead the driver may choose the magenta setting and halftone the rectangle as a representation of the pink color's lighter shade. To prevent the incorrect assignment of laser power, be sure to use the right colors. If using graphics with colors other than the eight listed above or to simplify the assignment of power settings, try using the B/W Raster feature in the driver. This feature will cause the system to only use the power setting assigned to the color black and halftone all of the other colors.

Outlines and Fills

The ULS Windows driver distinguishes between raster mode (engraving) and vector mode (cutting) by the type of graphic artwork being used. Basically all graphics other than outlines of very thin line widths will be interpreted as engraved images and the raster mode will be used for output. If laser cutting is desired, set the line thickness of the lines that are drawn in the graphics software to .001 inches or the smallest possible line thickness that is available. The printer driver will interpret these objects as vectors and will cut them out. The use of color fills or bitmaps will cause the laser system to engrave. The combination of engraving and cutting is available in most Windows graphics software. We suggest that when combining engraving and cutting objects, use different colors for the fills and outlines since engraving requires different power settings than cutting objects. One thing to keep in mind when creating cutting objects is that if the outline thickness is set too thick, the driver might interpret the outline as a filled object and will engrave the outline instead of cutting. At times this might be desirable if

engraving thick outlines is desired. The outline thickness at which the driver will interpret cut lines as filled objects is dependent on the software used. Usually, any line thickness .008 inches or greater will engrave. The only way to determine the cross over point for line thickness is to experiment with different line widths. Software programs that do not have outline capabilities will not have the ability to cut.

Image Processing Order

When cutting or engraving a graphic image, the laser system will perform all engraving first, then proceed to cutting. Engraving will proceed in the exact order of the colors listed in the driver. For example, all black filled objects will engrave first, then all red filled objects, then all green filled objects and so on. When all engraved objects have been completed, the laser system will proceed to cut any outlines present in the artwork. Unlike engraving, cutting will proceed in the order from which the outlines are drawn regardless of color. There are several different ways to control the order in which the outlines are cut. One way is to draw them in the exact order in which they need to be cut, but this is not always practical. Another way is to select the outline in the graphics software and “send it to the back,” behind the other objects, to cause the outline to be cut first. Bringing the outline “to the front” will cause that outline to cut last. A final way is to cut and paste each outline in the cutting order desired. This effectively works the same way as the two previous suggestions.

Overlapping Fills

If the artwork created has overlapping filled areas, the driver will automatically filter these fills to prevent the overlapped area from being engraved twice. This is similar to color separation in the printing industry. The entire filled area of the object on top will be engraved and only the visible part of the underlying filled area will be engraved. The final result is a what-you-see-is-what-you-get output. In this way the color white can be used as an effective drawing tool. Since the laser system will not engrave the color white (this is the background color), it can be used to block out the undesired engraving areas of filled regions and/or bitmaps.

Overlapping Outlines

The ULS Windows printer driver does not filter outlines that overlap each other. If placing one outline one on top of another, both outlines will be cut by the laser system. This is a useful feature that will allow deeper cutting by passing the laser over a single outline path twice or more. To take advantage of this feature, duplicate the outline on top of itself.

Hidden Vector Lines in Artwork

The ULS Windows printer driver does not automatically filter out outlines that are overlapped by engraved objects such as fills. If there are filled objects with some hidden outlines underneath the filled area, the laser system will then engrave out the fill and cut the hidden outline on top of the fill. This is a common occurrence when using pre-drawn ClipArt designed for laser printers. To prevent this from happening, turn on the B/W raster feature in the ULS Windows printer driver. This feature disables the cutting mode and converts all visible outlines to engraved objects and ignores all hidden outlines.

Optimizing Speed

It is advantageous to engrave an object in its longest direction because total engraving time will be reduced when the motion system has to make fewer stops and starts. If the engraving object is longer than it is tall, a greater engraving speed can be achieved by rotating the graphic 90 degrees and placing the material in the laser system sideways. Be aware that some graphics programs do not allow the rotation of bitmaps. In this case, it may be necessary to use bitmap image processing software to first rotate the bitmap before importing the bitmap into the graphics program.

If the artwork contains engraved objects of the same color with a great deal of space between them in the engraving direction, processing time can be longer since the laser must make long strokes to engrave both objects at the same time. To reduce engraving time in cases like these, use different colors for each of the objects but assign the same power setting to both colors. This will cause the laser to engrave one object at a time, skipping over all blank space, which in many cases will reduce engraving time.

Bitmaps

A Bitmap is a pattern of dots blended to form pictures much like the pictures in a newspaper. Most bitmaps are created by scanning artwork into a computer through a scanner. Others are created by drawing them in a bitmap image processing program. There are essentially two types of bitmaps that the laser system can utilize, monochrome and grayscale bitmaps. Monochrome bitmaps are one bit black and white images and grayscale bitmaps are 8 bit images. There is no advantage to scanning in or using color bitmaps because the ULS Windows Printer Driver converts color bitmaps into grayscale halftone patterns when printing. Color bitmaps consume a large amount of memory and are therefore **NOT** recommended. Monochrome bitmaps are used when scanning and engraving line art or camera ready black and white images. Grayscale bitmaps are used for scanning and engraving photographs.

When scanning black and white images, scan at the highest DPI that the scanner allows. The higher the DPI, the smoother the image will be. Scanning in at 300 DPI is the minimum recommended resolution for scanning line art (monochrome bitmaps), but 600 DPI provides a significant improvement in the image quality. Grayscale bitmaps usually should be scanned in at no more than 300 DPI. Scanning them in at a higher DPI does not effectively improve image quality and consumes large amounts of memory. As a rule of thumb, scan photographs at 300 DPI and line art images at 600 DPI. Feel free to experiment with different scanning resolutions and note the results.

There are several different bitmap formats available: TIF, BMP, PCX, and others. The format makes no difference to the laser system. The difference in formats involves how they are stored on the computer's hard disk. Bitmaps cannot be edited in most graphics software. Some basic functions such as cropping, scaling, or mirroring might be possible but it is usually necessary to use an image processing software to perform a dot by dot editing or rotation of the bitmap.

Bitmap images cannot be cut by the laser system only engraved. The only way to have the laser system cut out a bitmap is to first convert it to a vector file format such as an EPS. Raster to vector conversion programs are available that trace the bitmap (this only works well with monochrome bitmaps) and creates a separate EPS vector file. These EPS files can then be imported into the graphics program and printed out from there. Since tracing programs have many adjustments, some practice with them is necessary to produce desirable results.

Postscript Files

The laser system does not support Encapsulated Post Script (EPS) printing directly. EPS files can only be edited and printed if they are first imported into a graphics program. However, since EPS files do support engraving and cutting objects, they are therefore useful for transferring artwork from one graphics program to another. Once an EPS file has been imported into a graphics program, the objects can be outlined, stretched, rotated, mirrored, filled with different colors, or anything else desired. Be careful when using EPS files in layout software as opposed to true graphics software. Layout software may allow the placement of EPS files in the artwork but may not actually import and convert the EPS file to a useful format for the ULS Windows printer driver. The ULS laser system is not a postscript device. This means that postscript fills, postscript textures, and postscript fonts will not be able to print to the laser system.

3.2 THE ULS WINDOWS PRINTER DRIVER

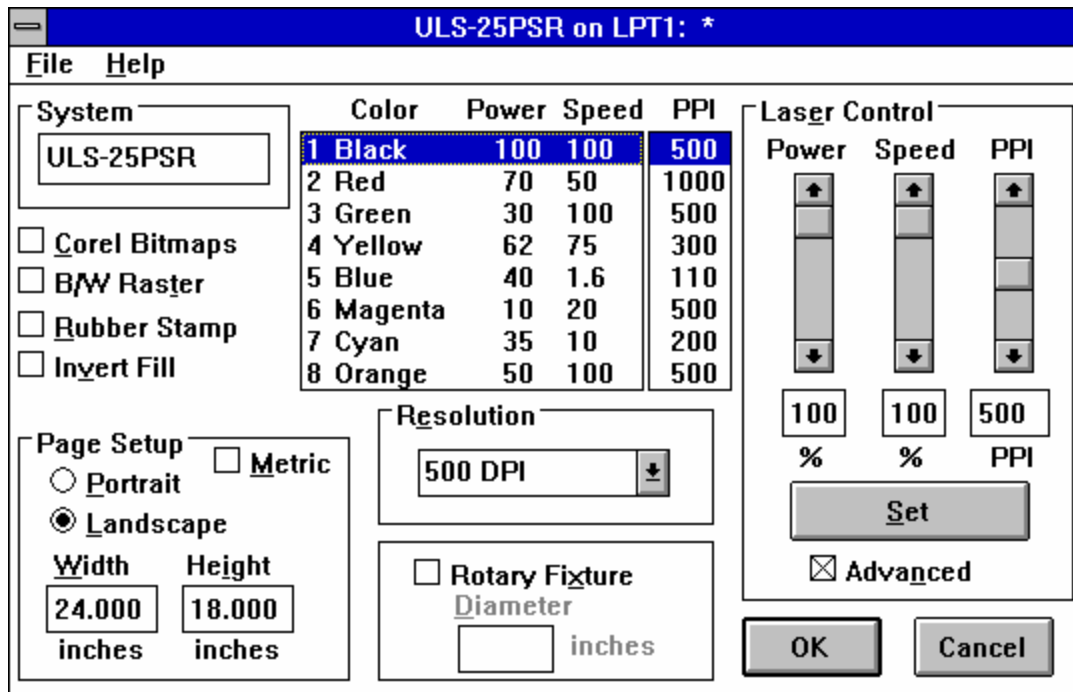

The ULS Windows Printer Driver

NOTE: When the following sections refer to turning a switch **ON**, this means putting an **'X'** in the box next to the driver selection desired. Turning a switch **OFF** signifies removing the **'X'** from the box. To change the **POWER**, **SPEED**, and **PPI** of a color, position the mouse arrow on the color and click once with the left mouse button. This will highlight the color and allow changing of the settings by using the scroll bars or highlighting out and typing in each setting. It is possible to set one color at a time or click on additional colors to set more than one at a time.

POWER SETTING

Laser power is controlled by assigning the percentage of power from 0 - 100% to each color used in the graphic drawing. Since the laser is proportionally pulsed, this percentage represents how long the laser remains on for each laser pulse fired. Basically, the power setting is directly related to how deep the engraving will be.

SPEED SETTING

This setting controls how fast the motion system moves in a percentage of the maximum speed of the system. For example, 100% **SPEED** is equivalent to 16.5 inches per second straight line velocity. Therefore, 10% **SPEED** is equal to 1.65 inches per second. When engraving, this is the rate in which the motion system moves back and forth. When cutting, this is the speed of the straight lines. If cutting curves or circles, the motion system automatically slows down. For example, there is no speed difference when cutting a circle at 50% or 100% **SPEED** because curves will run slower than straight lines even if it is set to 100%. Proportional pulsing of the laser will ensure that there is no difference in the depth of cut from straight lines to curves. Power and speed work together in determining how deep the engraving will be. Higher power settings and slower speeds will produce deeper engraving.

PPI

PPI stands for laser pulses per inch. This setting determines how many laser pulses, per linear inch, the laser system will fire. Again, since the laser system is proportionally pulsed, all pulses will fire equally spaced from one to the next regardless of changes in **SPEED**, **POWER**, acceleration, deceleration, or the cutting of curves. For example, when setting the **PPI** to 500 and using a standard lens that has a laser spot size of seven thousandths of an inch, significant pulse overlap will occur. The laser system fires a laser pulse and moves over two thousandths of an inch (that is 1 inch divided by 500). It then fires the next pulse and so on, overlapping the pulses significantly. Lines are formed by pulsing the laser pulses so close together and slightly overlapping each other that it appears to be a continuous line. Dot matrix printers work the same way except the laser system uses laser pulses instead of ink dots. When engraving, it is advisable to use a **PPI** setting of 500 or higher. If using less, the image resolution of the engraving is reduced. For cutting, a **PPI** of 150 and above can be used. Using less than 150 will result in the pulses being spread so far apart that they will not touch one another. This is a good example on how to perforate paper. Increasing or decreasing the **PPI** setting has absolutely no effect on engraving speed. The laser must either fire more quickly or slowly. Experiment with using different **PPI** settings on some scrap material when cutting or engraving and note the results.

SET

This button must be pressed after adjusting the **POWER**, **SPEED**, and **PPI** settings in order for these changes to take effect. If forgetting to click on **SET**, and clicking on the **OK** button instead, the settings will go back to the previous ones and will engrave the object with the incorrect settings.

ADVANCED

Turning this switch **ON** will permit the changing of the **PPI** settings. If the switch is turned **OFF**, the word **AUTO** will appear in the **PPI** column and will be colored gray. Since 500 **PPI** is the setting that is used most often, **AUTO** sets the **PPI** to 500 automatically and does not allow change unless the **ADVANCED** switch is turned back **ON**.

RESOLUTION

This setting is the image resolution of the engraving in **DPI** or dots per inch. There are six **DPI** settings to choose from: **500**, **250**, **250 x 166**, and **DRAFT**. The resolution can also be referred to as horizontal lines per inch or fill spacing. This is how many raster strokes per vertical inch of travel that the motion system steps down to produce an engraving. Higher resolutions will produce cleaner and deeper engraving but take longer to engrave. Lower resolutions produce a coarser and shallower image but are quicker to engrave. Experiment with the different settings and note the results.

COREL BITMAPS

This switch is for CorelDraw! users **ONLY**. Turn this switch **ON** only when there is an imported monochrome or grayscale bitmap in CorelDraw!. If printing any drawing that has a bitmap in it and forgetting to turn this switch **ON**, everything else except the bitmap will print. If the bitmap does not engrave, go back and turn the switch **ON**, select the bitmap only, and print Selected Objects Only in the software. Make sure to leave this switch **OFF** if there is no bitmap present. This switch should remain **OFF** if using software other than CorelDraw!.

B/W RASTER

This switch simulates laser printer output and is very useful if using a drawing with many colors, shades of gray, or many outlines. It is recommended to turn this switch **ON** when using ClipArt because there may be some underlying cutting lines hiding behind some filled areas. Having this switch **ON** gives a what-you-see-is-what-you-get output very similar to laser printer output. The entire drawing will be engraved, including all outlines, and only one power level will be used which is black. The color change ability of the driver is essentially turned off and all colors are engraved as different shades of gray. The laser system represents different shades of gray by producing a halftone pattern when engraving. Since ClipArt images use a wide variety of colors, shades, and outlines, the only effective way of engraving these images is to have this switch turned **ON**. B/W raster mode also provides greater compatibility with Windows software that do not work well with vector devices such as the ULS laser system. Call or fax our technical support if there seems to be a compatibility problem with a particular software program.

In order to engrave photographs and ClipArt that use colors and greyscales for shading, a halftone pattern must be created. A halftone is a series of dots arranged in a specific pattern. By varying the size and intensity of these dots, shading can be simulated in a process that is similar to that used to generate newspaper photographs. This same process is also used by black and white laser printers. There are two ways in which a halftone pattern can be generated. If printing directly from an image processing software, the halftone pattern can be assigned to the photograph or greyscaled scanned image before printing to the laser system. Sometimes this is referred to as setting the screen for printing. The other way is to let the ULS printer driver apply the halftone screen. The ULS printer driver automatically uses a 90 line per inch, 45 degree, round shaped halftone pattern if the **RESOLUTION** is set to **500**. A 45 line per inch, 45 degree, round shaped halftone pattern is automatically used if the **RESOLUTION** is set to **250**. If the imaging software being used is capable of producing its own halftone patterns, the characteristics of the pattern will need to be specified. Refer to the imaging software for more details about the direct printing of halftone patterns.

SOFTWARE OVERRIDE

Leave this switch turned **ON** at all times if planning to control the power through the Windows driver. If the switch is turned **OFF**, the power settings must then be manually input at the laser system.

PAGE SETUP AND ORIENTATION

Input here lets the ULS Windows printer driver know what page size and orientation is being used in the graphics software. These settings **MUST** match the graphics software settings **EXACTLY** otherwise no output, partial output, or misalignment of the graphic will occur. It is up to the operator to enter in the correct settings. Not only must the page size be **EXACT**, but the orientation must be the same also. Maximum page size is 17 inch width by 11.5 inch height in the Landscape mode. Select the Metric box if metric units are desired.

ROTARY FIXTURE

It is only necessary to use this selection if the optional Rotary Fixture has been purchased. For full details on how to use this option, please refer to section 4.6. Do not skip over to that section until the rest of this manual, up to that section, has been read. There is important information about the operation of the laser system that must be read before being able to fully understand and operate the Rotary Fixture.

RUBBER STAMP and INVERT FILL

These two selections will only appear in the driver if the Rubber Stamp option has been purchased. For a full explanation on how to use this option, refer to section 4.7. Again, please read the rest of this manual up to that point before attempting to use this option. A full understanding of how the laser system works is essential to producing correct results.

FILE

A unique feature of the driver is being able to store the power settings that are currently on screen. By selecting **FILE** and then **SAVE SETUP FILE**, all settings will be stored in a file that can be named as desired. The file extension, however, must remain as .LAS for the driver to recognize this file as a setup file. These files can be stored in any directory and may be retrieved by selecting **FILE** and then **LOAD SETUP FILE**.

The **LASER.INI** file can be thought of as being a file that stores the current power settings when the **OK** button is pressed. This gives the driver the ability to restore these settings every time the driver is accessed. Without this file, The power settings would have to be entered in every time the graphic is sent to print. Selecting **FILE** then **LOAD LASER.INI SETTINGS** will restore the settings that were saved the last time the **OK** button in the driver was pressed. Once the **OK** button is selected, the current power settings will be stored in the **LASER.INI** file and the original ones will be erased.

HELP

Select this option to access **HELP** on the use of the ULS Windows printer driver. Selecting **HELP** and then **ABOUT** will display the current driver version number and our copyright notice.

3.3 USING DOS BASED PROGRAMS

When using DOS based programs, there are a few things to keep in mind. DOS software is not standardized and each application will work differently. When using DOS applications, it is not possible to print through the ULS Windows printer driver and for this situation, the system has been designed to automatically emulate a Hewlett Packard plotter. Plotters use a special language called HPGL which the laser system has been designed to accept. When configuring the DOS based program, select the HP7475 plotter as the printing device. Set the maximum paper size to 17 inches wide by 11.5 inches tall (refer to the DOS software manual for how to configure the printing device). Once configured properly, the laser system should interface with the program very nicely and act just like a plotter. The following are a few points to remember when printing from DOS based programs.

1. Some DOS programs will not allow the page size to be set at 17 x 11.5 inches in the Landscape mode. If this is not possible, the full engraving field cannot be utilized. If a smaller page size is used, determine where the program will place the graphic on the engraving table by running a few tests to see where the laser system will output.
2. Some DOS programs use the lower left corner of the engraving field as the origin so remember this when setting up the graphic drawing.
3. When assigning power settings to the graphic, it will be necessary to assign an HPGL plotter pen to the different colors in which the graphic was drawn. In most cases the pen numbers should match the power setting numbers in the laser systems **POWER SETTINGS** display.
4. Some DOS programs may allow the setting of pen speed for the different plotter pens. These speeds will be ignored by the laser system so do not be concerned with making those settings in the software. The only place that the settings can be made is in the **POWER SETTINGS** display section of the laser systems control panel.
5. After every file download, an **END-OF-FILE** marker must be inserted at the laser system so that the buffer control will work properly.
6. Power setting for plotter pens can only be done at the laser system itself through the main control panel display. Section 4.2 of this manual will explain how to set the **POWER**, **SPEED**, and **PPI** settings for plotter pens. It will also describe how to insert an END-OF FILE marker and why it is necessary after every file download. Please refer to that section for more explicit details. If having trouble with using DOS based programs, please contact our technical support.

SECTION 4 - LASER SYSTEM OPERATION

4.1 GENERAL SYSTEM OVERVIEW

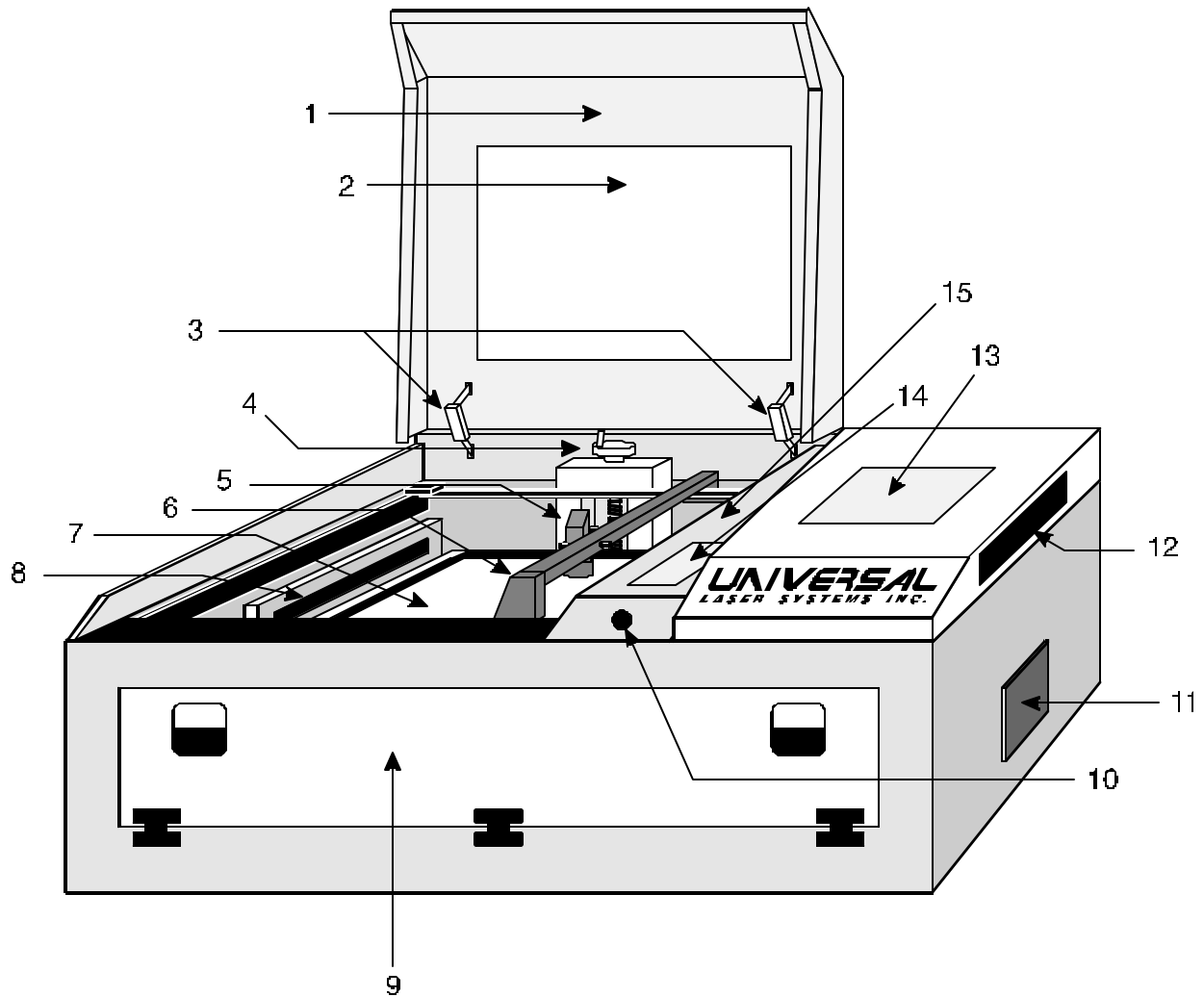

- | | |
|------------------------------------|---|
| 1. Top Door | 9. Front Door |
| 2. Top Door Window | 10. Interlock Defeat Tool Socket |
| 3. Top Door Counterbalances | 11. Air Intake Filter |
| 4. Engraving Table Adjustment Knob | 12. Parallel and Serial Connectors, On/Off Switch, Power Cord Inlet |
| 5. Focus Lens Holder Assembly | 13. Main Control Panel |
| 6. Motion System Y-Axis Arm | 14. Motion System Control Panel |
| 7. Engraving Table | 15. Motion System Protective Overhang |
| 8. Exhaust | |

4.2 THE MAIN CONTROL PANEL

The main control panel on the ULS laser engraving system provides easy access to all of the controls necessary for cutting and engraving operations. The control panel consists of a liquid crystal display (LCD), indicator lights, buttons, and a laser ON/OFF switch. The control panel is divided into three sections: Menu System and Controls, Process Controls and Laser ON/OFF controls.

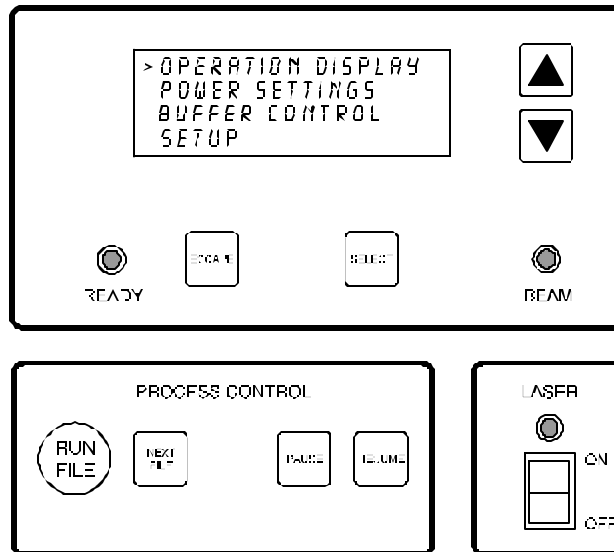

The four keys surrounding the liquid crystal display give complete access to the menu system. Use the up and down arrow keys to move the cursor up or down through the items on the display and press the **SELECT** key to choose an item. Some items on the display lead to other menus and some are settings that can be adjusted. After positioning the cursor on the desired item, press the **SELECT** key to access that item. The **ESCAPE** key allows backing up through the menu system to the main menu. The **ESCAPE** and **SELECT** buttons also function for changing a setting. The **SELECT** key accepts and stores the change and the **ESCAPE** key exits without changing the setting.

The green **READY** indicator light serves two purposes. It will illuminate to indicate when a job is completed and the system is ready to begin a new job, and if the **PAUSE** key is pressed, it will blink to indicate that the system is paused. When the laser is first powered on, the green light will blink until a job is run for the first time.

The red **BEAM** indicator light will illuminate when the laser is being pulsed. This provides a visual cue that the laser is firing. (NOTE: This indicator light actually signals that the main control board is sending pulses to the laser, so the light will continue to blink even if the power to the laser is turned off.)

The Menu system

```
> OPERATION DISPLAY  
POWER SETTINGS  
BUFFER CONTROL  
SETUP
```

All of the features built into the laser cutting and engraving system can be accessed and controlled through the menu system. The menu system is divided into four general areas each of which is accessed through the main menu. The main menu will display when the system is turned on. To access the submenus of the menu system from the main menu, select it with the cursor (move the cursor with the arrow keys) and press **SELECT**.

The OPERATION DISPLAY submenu

```
> OPERATION DISPLAY  
POWER SETTINGS  
BUFFER CONTROL  
SETUP
```

Then

```
> 1) BUFFER EMPTY  
#COPIES 0 0:00:00  
BLACK 100% SPEED  
100% POWER 500 PPI
```

This is the **OPERATIONS DISPLAY** submenu which will probably remain on most of the time during normal operation. It has been designed to show all pertinent operating information at a glance so that constantly jumping from menu to menu is not needed. The first line indicates that the laser system's print buffer is empty, but when the buffer is loaded with files, this line will display the currently selected file. To move to the next file in the buffer press the **NEXT FILE** button. Page through the list of files available in the buffer by placing the cursor on the first line of this display and pressing the **SELECT** button. The up and down arrow keys can then be used to move through the list of files in the buffer. When the desired file is found, simply press the **SELECT** key to make that file the current file. This will move the cursor back to the left hand side of the display. To run the currently selected file simply press the **RUN FILE** button. Changing the current file is not possible while running the laser system. No other items in this submenu can be selected or changed.

The **# OF COPIES** feature on the second line indicates the number of times the current file has been used since it was loaded into the buffer (the system keeps a running count of the number of times each file in the buffer has been processed). The second line also contains a timer to time files as they are run (this is useful for costing jobs). The timer will pause when the **PAUSE** key is pressed and starts up again when cutting or engraving has been resumed.

The last two lines show the power setting last used by the laser system. **BLACK** indicates the current power setting color used for all of the portions of the computer artwork which are colored black, **SPEED** indicates the speed of the motion system, **POWER** indicates the power output of the laser and the **PPI** setting indicates the laser's pulse rate (in this case 500 laser pulses per inch). The **OPERATIONS DISPLAY** mode is the part of the menu system that is used most often. In this mode, the file name will be displayed as well as the current power setting that the laser system is processing. When the laser system is first powered on and this submenu is selected, there will be an initial power setting displayed. Even after the first file is downloaded and the name of the file appears on the display, the power setting will still be unchanged. Please ignore these settings. Only until the file is run will the display show the correct power setting that was entered in the ULS Windows printer driver when the file was sent to print.

The **POWER SETTINGS** submenu

```
OPERATION DISPLAY
>POWER SETTINGS
  BUFFER CONTROL
  SETUP
```

Then

```
>POWER SETTING #WIN
  SPEED          100%
  POWER          100%
  RESOLUTION     500PPI
```

This submenu serves several purposes. The first purpose is to display the current power settings the laser system is using while it is running a job. This is very similar to the **OPERATIONS DISPLAY** submenu except that the name of the file running is not shown. Secondly, it is possible to change these settings while the laser system is running which is very useful for testing purposes. To adjust these settings, press the up or down arrow key until the cursor is on the desired selection. Press the **SELECT** key which moves the cursor to the right and then use the arrow keys to increase or decrease the values. Pressing the **SELECT** key again will accept the change and pressing the **ESCAPE** key will

restore it to the original setting. It is possible to adjust the settings while engraving on some scrap material until the desired **POWER**, **SPEED**, and **PPI** settings are obtained. Note these settings, change them in the ULS Windows printer driver and resend the file to the laser system for the final run. Lastly, the laser system allows eight different power settings to be saved in memory and used when processing a DOS based file. Since a DOS based printer driver is not available, the 8 power settings must be set manually on the laser system. Think of it as being able to assign laser **POWER**, **SPEED**, and **PPI** to the pens on a flatbed plotter. This is not necessary when using Windows since all settings can be set in the driver.

To access the power settings, press the **SELECT** key when the cursor is on **POWER SETTINGS**, then use the up and down arrow keys to scroll through settings 1 through 8. When the desired power setting number is found, press the **SELECT** key again to bring the cursor over to the left hand side of the display, and proceed to make the adjustments as previously described. If setting the **PPI** higher than **1000**, the laser system will display the word **"CONTINUOUS"**. This mode is used for maintenance procedures and is not used under normal operation.

NOTE: Do not use power setting **#WIN** because this power setting is used by the ULS Windows printer driver to temporarily store information during operation, and any settings stored there will be lost.

The **BUFFER CONTROL** submenu

```
OPERATION DISPLAY
POWER SETTINGS
>BUFFER CONTROL
SETUP
```

Then

```
> 1) FILENAME.XXX
INSERT END-OF-FILE
DELETE THE FILE
BUFFER SPACE 3.9MB
```

The laser engraving system comes equipped with a built in 4 megabyte memory buffer which is expandable to 16 megabytes. The buffer has built in file handling intelligence enabling each individual file in the buffer to be run in any order. The files are stored sequentially based on the order in which they were transferred from the computer and each one is assigned a number to help for tracking. A running total of the free space left in the buffer is provided at the bottom of the display. A small amount of memory is used by the system so there will never be a full 4 megabytes free. The file name displayed on

the screen is always the currently active file and there are two methods for looking through the list of files and choosing another file. The first method is to press the **NEXT FILE** button on the control panel. Each time the **NEXT FILE** button is pressed, the next file in the buffer becomes the current file. The second method is to point the screen cursor at the file name and press the **SELECT** key which will move the cursor to the right, then use the arrow keys to move backward or forward through the list until the file desired is displayed and then press the **SELECT** key again.

Eventually the buffer will fill up with files that will need to be removed from memory. It is possible to select each individual file and delete them one at a time. To accomplish this, make the desired file for deletion the current file in the same manner as previously described, then select the **DELETE THE FILE** option from the menu. To do this, use the up or down arrow keys until the cursor is pointing to that menu choice and then press the **SELECT** key. The display will then ask if you are sure and will expect a cancel or a yes response. To completely clear out the entire buffer all at once, bring the cursor down to the **BUFFER SPACE** option and press **SELECT**. The laser system will again ask if you are sure so respond accordingly.

Since the laser system is equipped with a unique way of storing multiple files in memory, special provisions are made to distinguish one file from the next. When using the ULS Windows printer driver, an end-of-file(EOF) marker is automatically sent to the laser system after each file is downloaded. An end-of-file marker is needed by the buffer in order for it to recognize the end of one file, the beginning of the next file, and to calculate the remaining free buffer space. Without an EOF, the buffer will not operate properly.

There are two ways that a downloaded file will have a missing EOF. The first is if printing through the ULS Windows printer driver and printing is canceled, interrupted, or file size exceeds the remaining free buffer space. When this occurs, chances are that the EOF never made it to the buffer and the buffer will show that it is empty or that the file does not exist. If this happens, part of the file might still remain in the buffer and that part might become mixed up with other files. This is when having an **INSERT-END-OF-FILE** option becomes important. In order to delete that partial file, the buffer must either be cleared entirely or an EOF must be manually inserted into the buffer by simply bringing the cursor down to the appropriate menu choice and pressing **SELECT**. This provides an alternative to clearing out the entire buffer by inserting the EOF marker at the end of the unwanted file fragment. Next, press the **NEXT FILE** button and this fragment will then show up on the display as **NONAME** and will allow its solitary deletion without having to delete the other files in the buffer.

Secondly, when using DOS based programs, a printer driver other than the ULS Windows printer driver must be used. That driver does not know to send down to the laser system the required EOF marker at the end of file downloading. Again, the buffer will not recognize that the file exists because it does not see the end of it. In this case, an EOF must be manually entered into the buffer after each and every file download from a DOS based program. Since the file name is not sent to the laser system by a DOS based printer driver, every file will be called **NONAME**. To distinguish one **NONAME** file from the next, the display will number the files in the order from which they were downloaded.

The SETUP submenu

```
OPERATION DISPLAY  
POWER SETTINGS  
BUFFER CONTROL  
> SETUP
```

The **SETUP** menu choice allows laser system reconfiguration. Selecting this option will lead to other menu choices.

```
> TICKLE  
CONFIGURATION  
DIAGNOSTICS  
RETAIN SETTINGS
```

Then

```
> TICKLE RATE    5KHZ  
TICKLE WIDTH    1 μS
```

TICKLE is the term used for small pulses which are fed to the laser to keep the plasma inside energized. This allows the laser to respond quickly for high speed cutting and engraving. The tickle is preset at the factory and usually will not require adjusting. However as the laser ages it may become necessary to change these settings to maintain peak performance.



WARNING:

Do not attempt to adjust the **TICKLE** setting. Consult the ULS technical staff first to determine whether it is necessary.

```
TICKLE  
>CONFIGURATION  
DIAGNOSTICS  
RETAIN SETTINGS
```

The **CONFIGURATION** selection allows the reconfiguration of certain features of the engraving system. Selecting this option will lead to other menu choices.

```
>AUTO POWER      ON  
BUZZER           ON  
PORTS  
LOAD DEFAULTS
```

AUTO POWER and **BUZZER** menu options can be toggled either **ON** or **OFF** by placing the cursor on the appropriate menu choice and pressing **SELECT**. The **AUTO POWER** feature allows the laser system to change power settings while it is cutting and engraving a file. If this feature is **ON** (the default setting), the power settings will change in response to different colors used in the artwork (or in the case of DOS applications different pen numbers assigned to the artwork) as described earlier in the section on the power settings display. If this feature is turned **OFF**, the system will use the current power setting selected in the **POWER SETTINGS** menu and no power changes will take place.

```
AUTO POWER      ON  
>BUZZER         ON  
PORTS  
LOAD DEFAULTS
```

The **BUZZER** option emits a sound to indicate when a file has finished running and may be turned **OFF**.

```
AUTO POWER      ON
BUZZER          ON
>PORTS
LOAD DEFAULTS
```

Two ports are provided on the right side of the system for interface with a computer, a serial and a parallel port. Only one port can be used at a time. To activate a port, select **PORTS** from this menu and one of the following sub menus will appear:

```
>PARALLEL
```

or

```
>SERIAL
BAUD RATE      9600
STOP BITS      1
PARITY         ODD
```

The menu that appears indicates the currently active port on the laser system. To switch to the other port press the **SELECT** key. In order to use the **SERIAL** port the communication settings **MUST** match those of the computer. Refer to the computer's hardware and software manuals for details on setting up the computer's serial port.

If using the **SERIAL** port, select the fastest possible **BAUD** rate for communication since this effects how quickly the computer can send files to the laser system. For **BAUD** rates of **9600** and above, set the number of **STOP BITS** on the computer to a higher value than the number of **STOP BITS** selected on the laser engraving machine. For example if the number of **STOP BITS** on the laser engraving system is set to **1**, then set the computer's stop bits to 1.5 or 2.

PARITY of the laser system and the computer **MUST** match exactly and the choices are **ODD**, **EVEN**, or **NONE**. Pressing the **SELECT** key while the cursor is on **PARITY** will toggle through these choices.

```
AUTO POWER      ON
BUZZER          ON
PORTS
>LOAD DEFAULTS
```

The **LOAD DEFAULTS** selection on the last line returns the system to its factory default settings.



WARNING:

Do not select the **LOAD DEFAULTS** menu selection without first consulting a ULS technical support representative.

```
TICKLE
CONFIGURATION
>DIAGNOSTICS
RETAIN SETTINGS
```

The **DIAGNOSTICS** selection allows the testing of certain features of the engraving system. Selecting this option will lead to other submenus.

```
>TEST MEMORY
PLACE 17000X 11500Y
UNIVERSAL LASER SYS.
COPYRIGHT 1994 04-10
```

It may be necessary to use the diagnostic tests if instructed to do so by a member of the ULS technical support staff. The first line on the menu display is a buffer memory test but in the process of testing memory all files in the buffer will be erased. Once the memory test is started it will continue to run until it is canceled. The second line displays the current position of the motion system in motion system units. Each unit represents a single step of the motion system motors. The final two lines are a copyright notice.

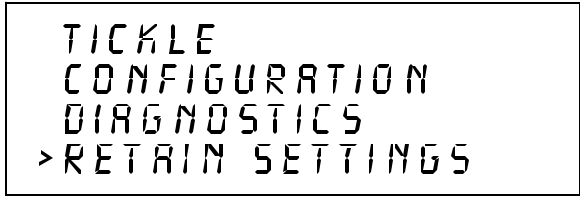

By selecting **RETAIN SETTINGS**, any and all changes made to the display settings will be permanently stored even if power is turned off to the laser system. Those settings will be retained in the laser system until they are changed and **RETAIN SETTINGS** is selected again.

THE PROCESS CONTROLS

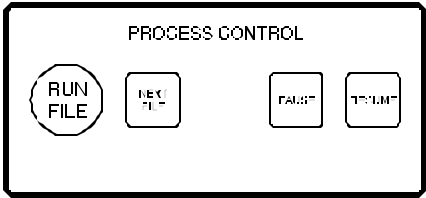

RUN FILE



Press the **RUN FILE** button to start cutting or engraving the current file in the system buffer. Do not press the **RUN FILE** button while the system is cutting or engraving a file; either pause the system or wait until it has completed the job.

PAUSE AND RESUME

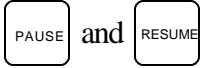

The **PAUSE** button can be pressed while the system is cutting or engraving a file to pause all operations. When paused, the motion system arm will move to its home position under the protective overhang. When ready to resume operation, press the **RESUME** key and the system will begin cutting or engraving again where it left off. The **READY** indicator light will blink when the system is paused.

NEXT FILE



Pressing the **NEXT FILE** button brings up the next file in the system buffer and makes it the current file. Pressing the **RUN FILE** button starts cutting or engraving of the file. (Do not press the **NEXT FILE** button while the system is cutting or engraving a file; either pause the system or wait until it has completed the job.)

THE LASER CONTROLS

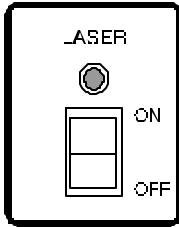

The **LASER ON/OFF** switch allows the laser's power to be turned on and off manually for emergencies. The red indicator light will light up when power is being supplied to the laser. The indicator light is also tied in with the safety interlock system, so the light will go on and off as the doors to the system are opened and closed.

4.3 MOTION SYSTEM CONTROLS

The motion system control panel, accessed when the top door is open, allows the positioning of the motion system in order to use the focusing tool. The functions of the keys are described below.

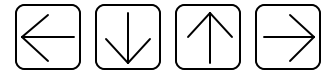

POSITIONING KEYS

Use these keys to move the motion system in the indicated direction. Pressing two adjacent keys together moves the focus lens carriage in a diagonal direction.

FAST KEY



Pressing this key together with an arrow **POSITIONING** key increases the speed at which the motion system moves.

REFERENCE POINT KEYS - P₁ AND P₂



Press the P₁ or P₂ key to move the motion system to the lower left or upper right corners of the engraving area, respectively.

AUX KEY



This key is currently not in use.

TEST KEY



This key turns the laser beam on and off. This key is used for maintenance procedures only and is not operational without the use of the interlock defeat tool.

4.4 LOADING AND FOCUSING THE LASER SYSTEM

Loading materials

The first step to laser engraving is loading the material and focusing the laser beam on the top surface. Let's use a 4 x 6 inch wooden plaque as an example. Open the top door and place the wood on the engraving table. Rotate the wood so that the longest direction is in the horizontal direction. Slide the wood into the upper left hand corner of the engraving table against the horizontal and vertical rulers.

Materials larger than 17 x 11.5 inches can be processed provided they fit into the machine and allow all the doors to be closed properly. Space is provided within the system for material to hang over the right edge of the engraving table and pieces of up to 30 inches in length can easily be processed. If you have an application of this type, load the material through the front door of the system. However, all the doors must be able to close before cutting and engraving. Do not attempt to defeat the interlock system in order to process materials too large to fit into the system as this could result in exposure to laser radiation.

To process more than one piece of material at a time, such as in a production application, a template can be easily made to help in loading the system. To make a template draw a slightly oversized outline of the material to be processed and duplicate it as many times as will fit into the 11.5 x 17 inch field. Place a piece of 11.5 x 17 inch material such as paper, acrylic, or cardboard on the engraving table and cut the outlines into the material. Position the engraving objects within the template outlines. Now position the graphics on screen so that they are aligned within the template outlines. Finally, print only the graphics and not the outlines to the laser system. A convenient template has now been made for quickly loading the system.

Focusing the laser beam

In order to cut and engrave with precision the laser beam in the laser engraving system is focused to a small spot by the focus lens. This focused beam is 2.5 inches below the lens (for the standard lens provided with the system).

1. Turn the laser system on and move the motion system using the arrow keys on the motion system control panel until the focus lens holder assembly is positioned over the plaque.
2. Move the engraving table up or down by turning the engraving table adjustment knob until the base of the focusing tool can be placed on the top surface of the material to be processed and the flat of the focusing tool can be placed flat against the side of the lens holder as in the diagram below.

3. Observe the top of the focusing tool. Now raise the engraving table until the focusing tool just starts to tilt away from the lens holder as shown in the diagram below. Back the engraving table down again slightly so the focusing tool again sets flat against the side of the lens holder. The point in which the focusing tool just starts to tilt away is the optimal focus distance.

NOTE: The focal length of the optional high resolution focus lens is 1.5 inches. A high resolution focus tool must be used with this lens.

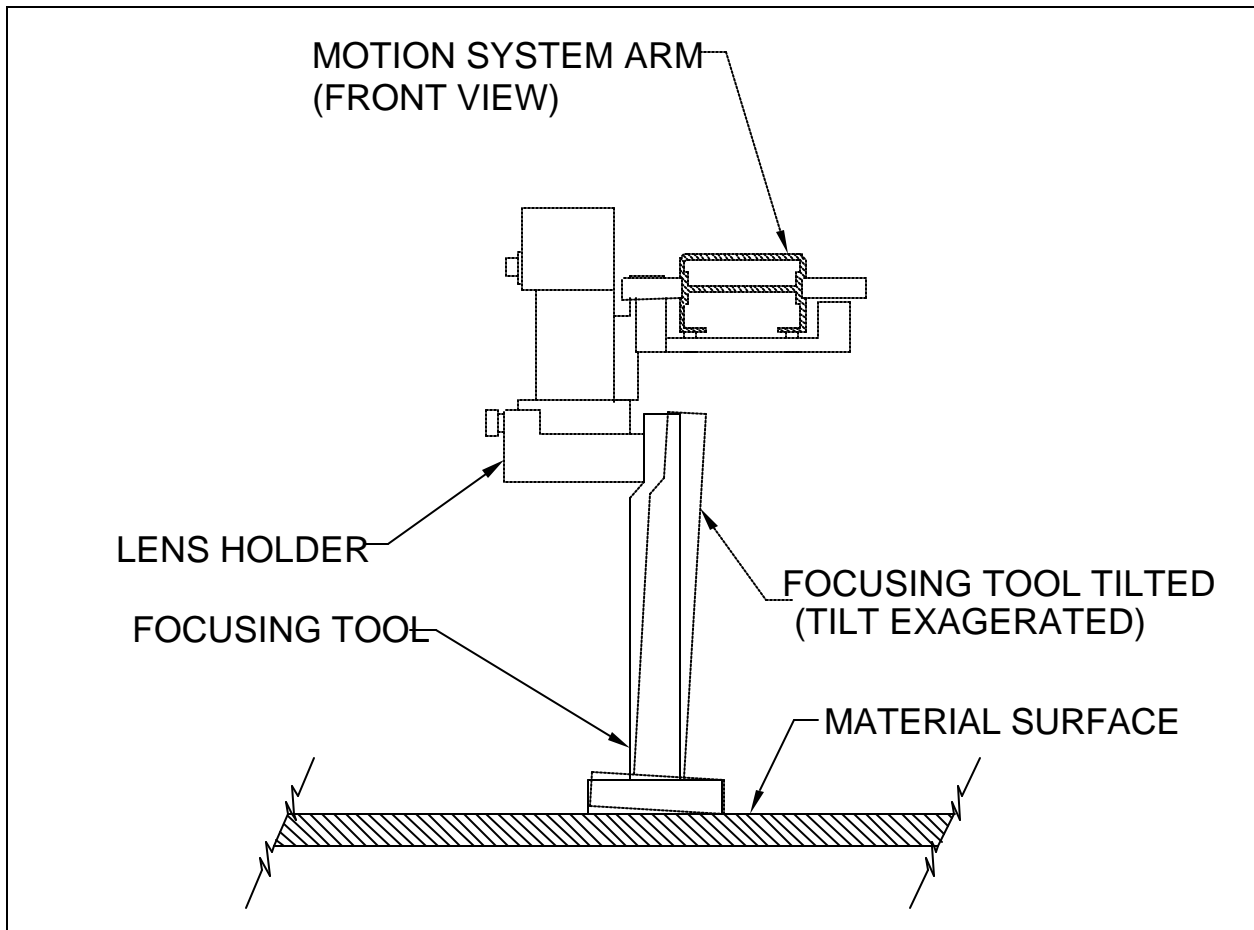

4.5 RUNNING A SAMPLE

The following outline is a step by step procedure used to produce a laser engraved object. Please follow this procedure to understand the steps necessary for laser engraving.

- STEP 1** Turn on the computer and then the laser system. Be sure to turn the equipment on in this order.
- STEP 2** Load the object that will be engraved into the laser system and position it in the desired location in the engraving area. Usually, the object is placed up against the rulers in the upper left hand corner of the engraving area. Use the rulers to determine the size of the engraving object. Use either the top door or the front door for loading.
- STEP 3** By using the motion system control keys, position the focus lens assembly over the engraving material. Adjust focus by using the focusing tool and adjusting the height of the engraving table.
- STEP 4** Create a graphic using the graphics software program and position the graphic on screen so that it matches the placement of the object in the laser system.
- STEP 5** Before printing, go to the ULS Windows printer driver and assign the power settings. If using DOS based programs, go to the laser system and enter in the power settings on the main control panel.
- STEP 6** Now send the file down to the laser system.
- STEP 7** Turn on the exhaust blower.
- STEP 8** Finally, when the file is in the laser system's buffer, press the **RUN FILE** button to start engraving.
- STEP 9** While the laser system is running, start setting up the next job.

4.6 USING THE OPTIONAL ROTARY FIXTURE

The Rotary Fixture controls in the ULS Windows printer driver are used along with the optional Rotary Fixture to engrave onto round or cylindrical objects. In order to compensate for different diameter objects, the image must be adjusted. This is done automatically by the ULS Windows printer driver when selecting Rotary Fixture and entering in the diameter of the object being engraved.

The rotary fixture allows the engraving of cylindrical work pieces up to 4.75 inches in diameter (5.75 inches with the high resolution lens attached) and up to 12.5 inches long. Two attachments come with the fixture, a cone shaped disk attached to the motorized end of the fixture and a flat disk with foam padding attached to the adjustable end of the fixture. These attachments are designed to hold wine glasses, mugs, cups, etc. The following is a step by step procedure in the installation and operation of the Rotary Fixture. We are going to use a glass as an example.

Installation of the Rotary Fixture

1. Turn the laser system **OFF**. Open the top door of the laser engraving system and place the Rotary Fixture on the engraving table with the black box on the Rotary Fixture to the right.
2. Attach the Rotary Fixture to the engraving table by sliding the U shaped pivot block clamps onto the engraving plate. Before tightening the thumbscrews, slide the fixture towards the top of the engraving area as close to the top ruler as possible. Position the fixture so that it is squarely aligned with the rulers. Being square to the rulers will ensure that the fixture is square to the engraving area. The rulers also provide a visual guide as to where to locate the graphic in the graphics software. From underneath the plate tighten the thumbscrew clamps so that the fixture is secured to the engraving table.

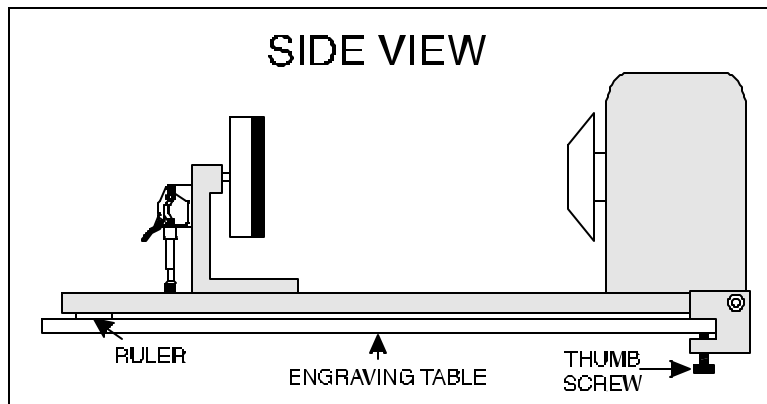

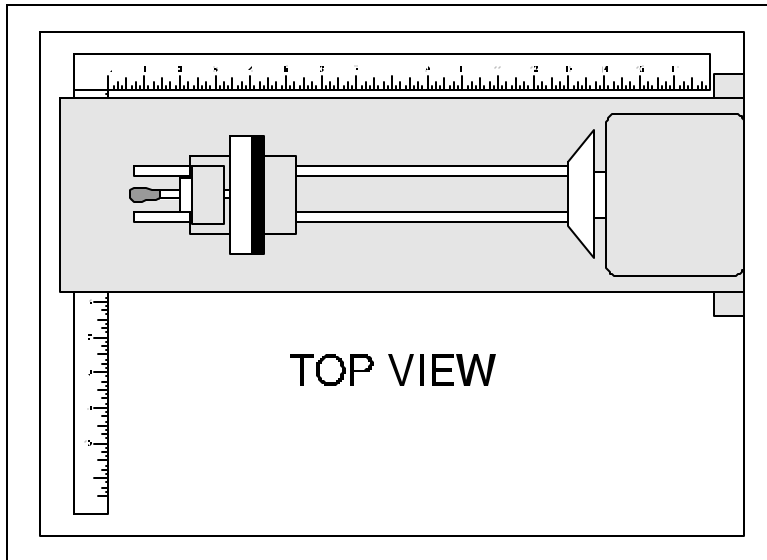

3. Connect the Rotary Fixture control cable to the connector on the laser engraving system. To find the connector, follow the ribbon cable which moves with the main arm of the motion system back to its source on the side wall up underneath the protective overhang for the main arm of the motion system. Mounted on that side wall is the connector which the motion system ribbon cable plugs into. The connector has two locking clasps which snap in place. Open the clasps and disconnect the motion system cable, then plug the Rotary Fixture cable into the connector. The connector is keyed so the cable cannot be installed incorrectly. The end of the Rotary Fixture control cable has two plugs but only one will fit.
4. Plug the motion system cable into the free receptacle on the Rotary Fixture cable. When finished, the Rotary Fixture cable should be plugged into the laser engraving system and the motion system cable should be plugged into the Rotary Fixture cable. Refer to the diagram below.

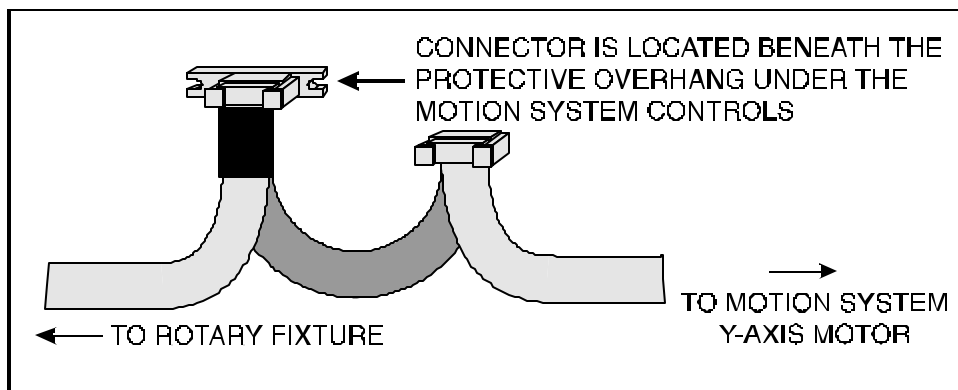

5. Before loading the glass into the fixture, measure the diameter of the glass in the area where the engraving is to be located by using a caliper or similar measuring device. Remember this number or write it down.
6. Place the open end of the glass on the right side of the Rotary Fixture. Lift the lever on the adjustable end of the fixture and slide it up against the other end of the glass so the glass rests firmly against the padded foam disk. Do not apply too much pressure, especially with glass. Lower the lever on the adjustable end of the fixture to secure it in place.

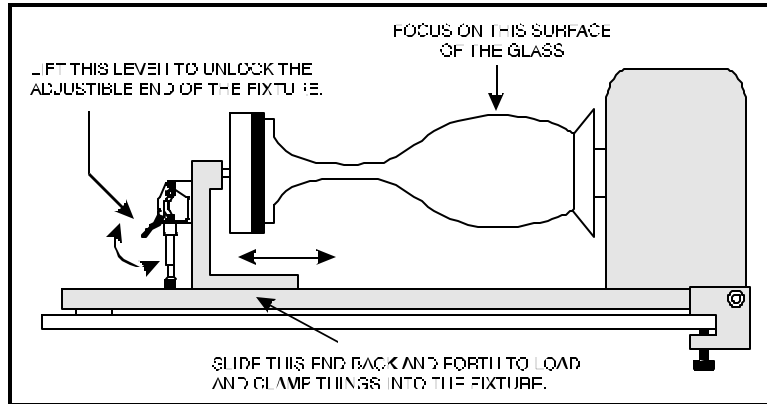

7. The motion system must now be manually aligned with the Rotary Fixture. While the laser system is still turned **OFF**, gently pull out the Y-axis arm from underneath the protective overhang. Then slide the focus lens carriage so that it is visually aligned and centered along the Rotary Fixture's axis of rotation. Now focus on the glass using the focusing tool. If the glass slopes too much in the engraving area, the Rotary Fixture can be tilted upwards to make the surface of the glass parallel with the motion system. To do this, lift up the left end of the fixture and place some sort of spacer underneath the fixture to prop it up. Be careful not to raise the Rotary Fixture too high, otherwise it might interfere with the motion system.

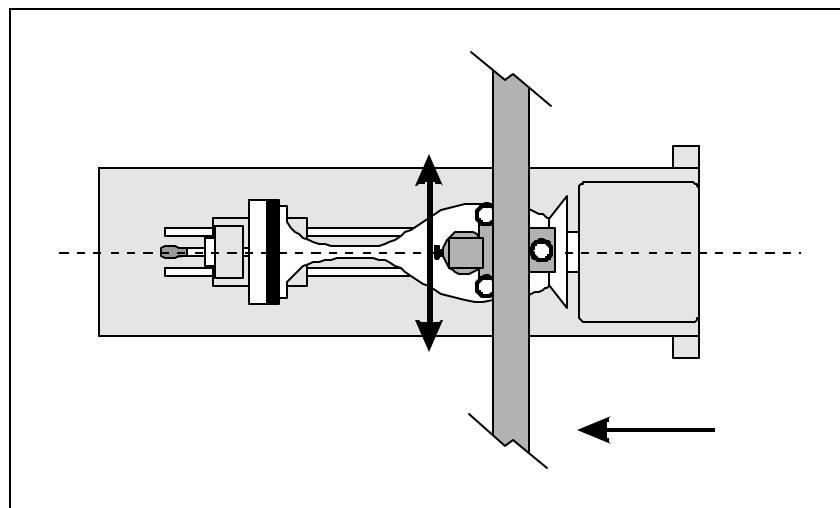

8. The laser system is now ready to be powered up. Turn on the laser and note that when the laser system goes through its homing procedure, the focus carriage does not move but the Y-axis arm slides all the way to the right. This is because the Y-axis motor has been disconnected when the Rotary Fixture was installed. This is how the Rotary Fixture engraves an object by the rotation of the object around a fixed axis while the Y-axis arm moves left to right.

Operation of the Rotary Fixture in the Landscape mode

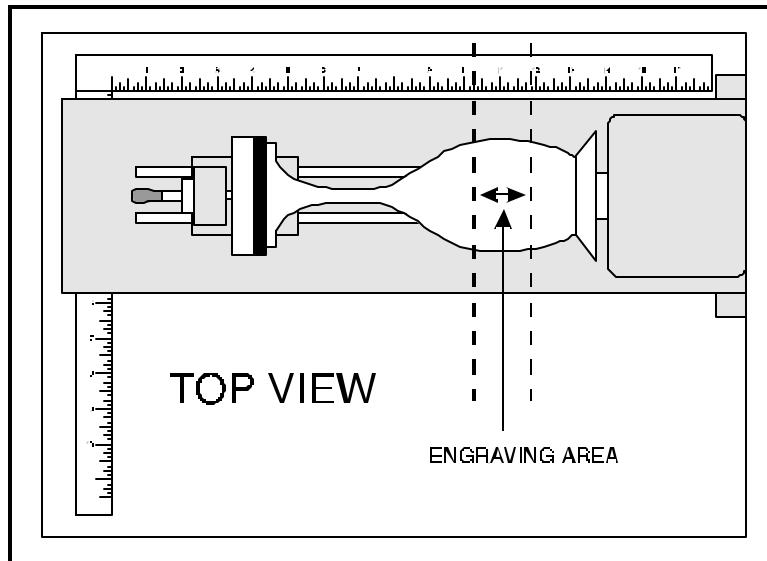

1. Use the top ruler as a visual aid in referencing the engraving area of the glass. Sometimes using a ruler placed up against the glass and at a right angle to the table rulers will help with determining the engraving area. Note this area because it will be used in designating where to place the graphic on the computer screen.
2. In the driver, make sure that the Page Setup is set to Landscape and the size set to a width equal to 17 inches and a height of 11.5 inches. Then click on the **Rotary Fixture** selection box and type in the diameter that was measured. Notice that while typing in the diameter, the size of the height dimension changes automatically. Click on **OK** and go back to the graphics software's page setup and change it to **EXACTLY** match the new page size that the ULS Windows printer driver established when the diameter of the object was typed in.
3. This new vertical page size is now the actual circumference of the object that is going to be engraved. From the top of the engraving area (on screen) to the bottom represents one complete revolution of the Rotary Fixture. For example, if engraving a glass that has a diameter of 3.075 inches, the driver calculates that the circumference (and vertical page size) is 9.66 inches.

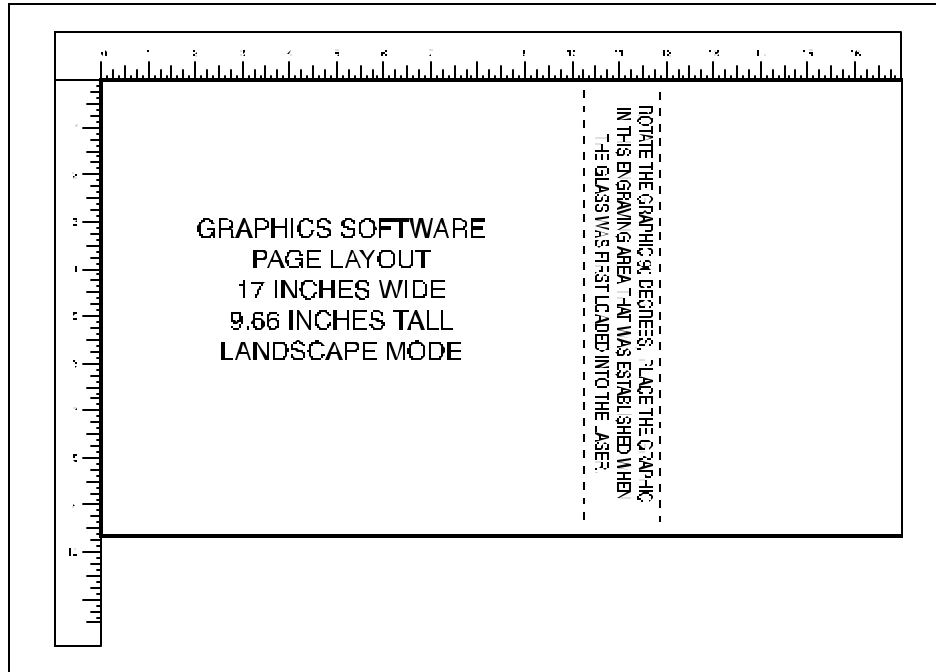

4. Position the graphic, on screen, so that it will fit vertically within the new page height and horizontally within the engraving area of the glass. If the graphic does not fit within the vertical page size limits, the portion that is outside the page limit will not engrave. Remember, the new page size that the driver calculates from the diameter of the glass is it's actual circumference. From the top of the page down to the bottom is one complete revolution of the glass. Since the Rotary Fixture will not turn more than 360 degrees, make sure that the graphic lies between the page limits.
5. Set the driver parameters, send the file to print, and begin engraving.

Operation of the Rotary Fixture in the Portrait mode

1. The Rotary Fixture can also operate in the Portrait mode providing that the engraving object is not too heavy. The Portrait mode will cause the Rotary Fixture to spin the object back and forth very quickly. The normal Landscape mode will rotate the object very slowly and raster the Y-axis arm from left to right very rapidly. Landscape mode usually takes longer to engrave than Portrait mode because the usual engraving area is taller than it is wide. If using Portrait mode, make sure to engrave at speeds lower than 50 % otherwise the object might slip as the Rotary Fixture spins back and forth. If the object slips, it is either too heavy or the engraving speed is too fast. To use the Portrait mode, simply click on Portrait in the graphics software's page setup and then in the ULS Windows printer driver.

- The graphic on screen will now need to be adjusted. The graphic will have to be rotated another 90 degrees so that the graphic is upside down. Reposition it within the defined engraving area as the diagram below illustrates.

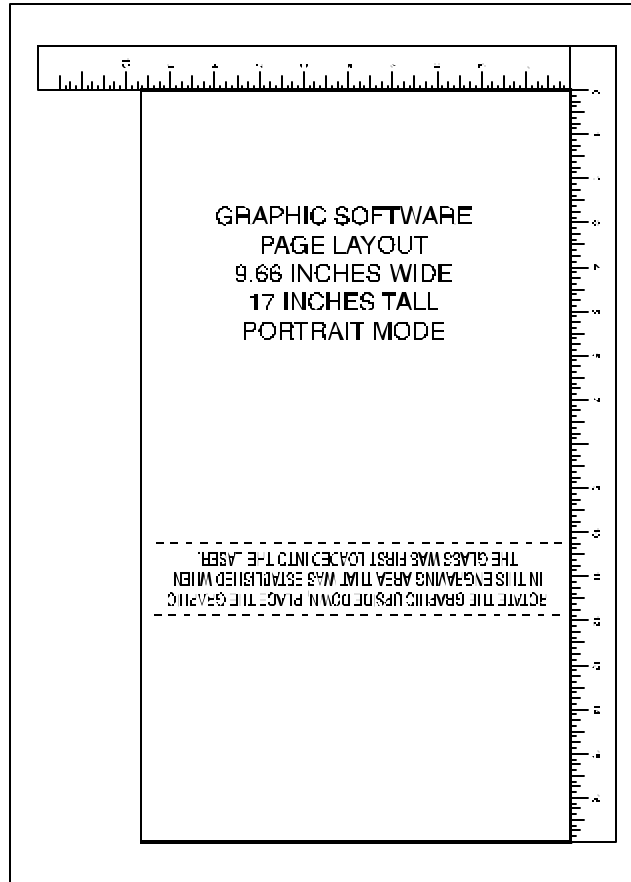

- Do nothing to the Rotary Fixture inside of the laser. The setup on it is the same as in Landscape mode. Experiment with using both the Landscape and Portrait modes and note the results.

NOTE: Remember that the new page size that was established by the driver when the objects diameter was entered in indicates the circumference or distance around the outside of the object. Be sure to go back and adjust the graphics programs page size to match these new dimensions **EXACTLY** otherwise the graphic will engrave in the wrong place, engrave only partially, or not engrave at all.

4.7 THE RUBBER STAMP OPTION

There are two switches in the ULS Windows printer driver which manage the rubber stamp option, the **RUBBER STAMP** switch and the **INVERT FILL** switch. The **RUBBER STAMP** selection taper profiles the engraving and automatically mirrors the entire page about it's centerline. The **INVERT FILL** switch will turn the entire page into a negative while it is printing. This image inversion causes the laser system to engrave out the background and leave the characters standing up. The **INVERT FILL** selection is only used when engraving a full sheet of stamps because it creates the negative image for the entire sheet, not just an individual stamp. Selecting both features allows the user to create a full sheet of rubber stamps as a positive and unmirrored image on screen. Since there are several different methods in creating and producing rubber stamps, we will give just a few examples to follow so that the process becomes fully understandable. Experiment with the different techniques and choose the method most desired.

To create the artwork and engrave only one or a few stamps, set the page size in the graphics program to something smaller than the full field. Just as an example, we will use a page size that is 8.5 x 11 inches in the Landscape mode. In this way we can output to a paper printer, before engraving, for proofreading. Do not use the full 17 x 11.5 inch size for one or a couple of stamps because printing time will be longer. Make sure that this page size is set up the same in the ULS Windows printer driver. Draw a black box slightly larger than the size of the stamp desired. Type in or add graphics within that area and color them with a fill of white. It is not necessary to mirror the image. Then draw a red outline box (.001" line thickness) for the cut. An example is shown below.



Since the driver automatically mirrors the entire page when the **RUBBER STAMP** option is selected, be aware that the stamp will engrave on the opposite side of the page. As an example, position the stamp in the upper right hand corner of the page and place a full sheet of rubber in the upper left side of the engraving area inside the laser system. We recommend installing the High Resolution lens for engraving rubber stamps. Focus on the material using the correct focusing tool and go to the ULS Windows printer driver to set the power settings. There are some sample settings in section 4.8 of this manual for rubber stamps. They might have to be adjusted for different types of rubber and thicknesses. When selecting **RUBBER STAMP** in the driver, notice that the **INVERT FILL** switch automatically becomes selected. Deselect the **INVERT FILL** option because it will not be used in this

example. The following diagram shows an example of setting up the graphics software's page layout and positioning the rubber engraving material inside the laser system respectively.

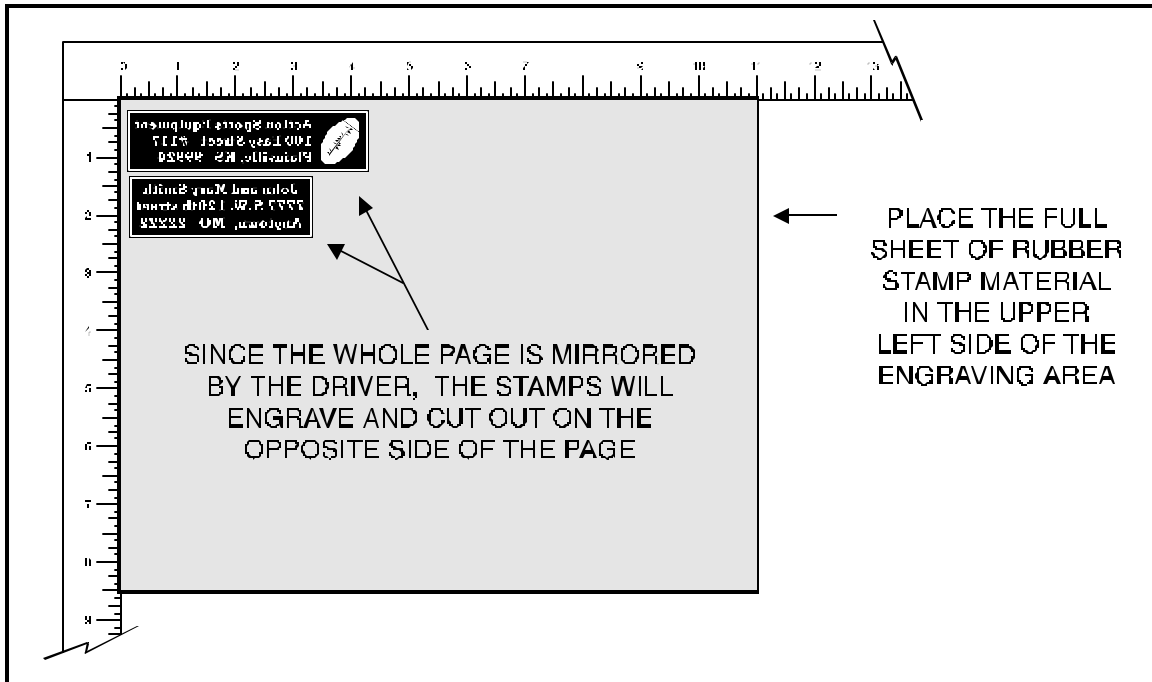
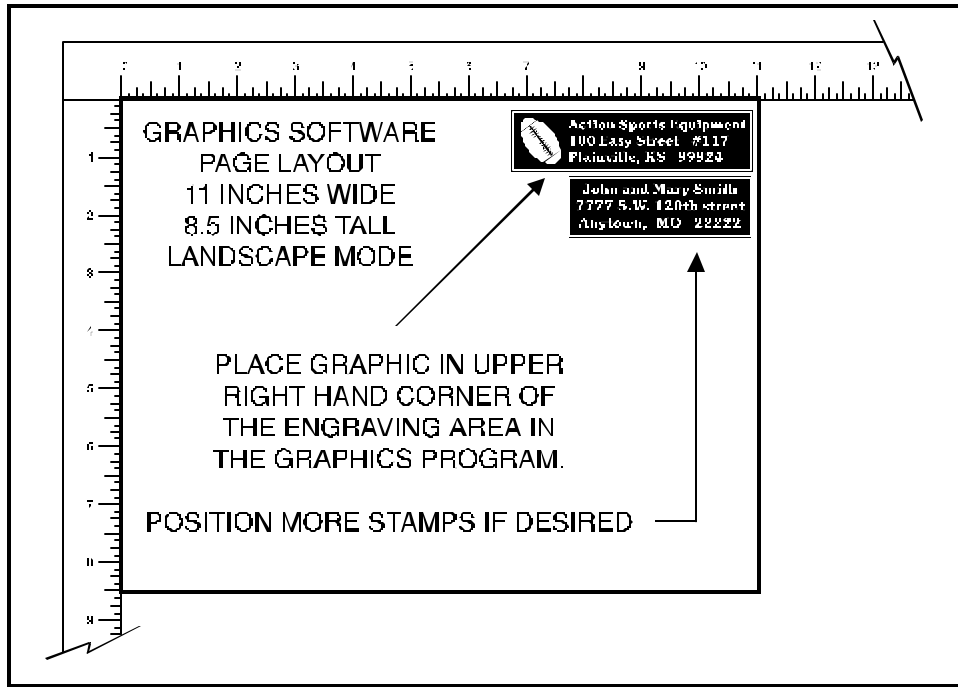

After making all driver selections, print the graphic to the laser system. Start engraving and notice that the stamps are being engraved as a mirrored image and are in the correct position on the rubber sheet. The background area, since it is colored black is being engraved and the letters remain standing up.

When all engraving is done, the stamp gets cut out along the red cut line due to the higher power setting that was assigned in the driver for the color red.

The second method is to create a full sheet of rubber stamps and engrave them all at the same time. First create a stamp as a positive image as shown below. Create more stamps to fill the entire page.



If desired, output the page to a paper printer for proofreading. Printing out a positive image to a printer is easier to read and uses less toner or ink than a negative print. Go to the ULS Windows printer driver and select **RUBBER STAMP** and leave the **INVERT FILL** selection **ON**. Set the power settings and print to the laser system. Position the full sheet of rubber stamp material in the same upper left location on the engraving table and begin engraving. The driver automatically mirrors the entire page, profiles all of the characters, and creates a negative image for engraving.

Printing Speed

When printing a large number of rubber stamps on one page it can take quite a bit of time to generate the print file. This is because the calculations required to produce a profiled shape take much longer than those required for a non-profiled shape. However, there are things that can be done to control the printing time:

- Use as few fonts as possible. The more fonts used the longer it will take to generate a print file.
- Use the automatic invert fill feature whenever possible. Manually inverted images with many black backgrounds will take longer to print.
- Use the minimum page size necessary to produce the stamps desired. Larger pages take longer to print.
- If possible, upgrade the computer system. A faster computer processor will produce faster print times.

4.8 START UP PARAMETERS FOR VARIOUS MATERIALS

This section provides driver settings and helpful hints to get started engraving and/or cutting various materials. These settings are to serve as a starting point and are not necessarily optimized for each particular application. There are many variables that can affect the cutting and engraving process such as differences in the thickness of the material, density of the material, composition of the material, and the manufacturing processes used to make the material. Please use these settings as a guideline, in most cases these settings should work out well, but sometimes may have to be adjusted to produce desirable results.

In compiling these settings, all samples were run with the fill spacing set at **2** and the **HIGH RESOLUTION** switch in the driver turned **ON** (except were otherwise noted). When using a larger fill spacing in order to achieve greater engraving speeds, remember that the resolution will be reduced which in turn will reduce quality and depth. In order to compensate for lower resolution settings (larger fill spacing), lower the speed and/or increase the power to achieve the same depth.

Below is a list of the various materials that were tested. The following pages will fully describe the results of these tests and will offer helpful hints when choosing materials, setting parameters, and using different techniques to provide the best laser cutting and engraving results.

ACRYLIC - CAST AND EXTRUDED
ACRYLIC - MIRRORRED
ALUMINUM - ANODIZED
BRASS - COATED
CORIAN OR AVONITE
CORK
GLASS
LEATHER
MARBLE
MAT BOARD
MELAMINE - PHOTO/CLIPART ENGRAVING
MELAMINE - STANDARD ENGRAVING
PLASTIC - ENGRAVERS
RUBBER STAMPS
VINYL - SIGN
WOOD - FINISHED WALNUT
WOOD INLAY - VENEERS

ACRYLIC - CAST AND EXTRUDED

TYPE	POWER	SPEED	PPI	PASSES	DEPTH
RASTER ENGRAVING (light)	20	100	500	1	.001"

COMMENTS:

Remove original factory masking from the engraving surface. Leave the masking on the non-engraved surface to prevent accidental scratches.

TYPE	POWER	SPEED	PPI	PASSES	DEPTH
RASTER ENGRAVING (deep)	100	100	500	1	.010"

COMMENTS:

This sample engraved deeper than the first sample. Engrave through original masking. Engraving too deep will loose detail.

TYPE	POWER	SPEED	PPI	PASSES	DEPTH
VECTOR CUTTING	40	1	500	2	.125"

COMMENTS:

For the best results, remove the original masking on both sides. Re-mask with transfer tape. Moisten both sides with water from a spray bottle. Elevate the material at least 1/8" off of the engraving table.

ADDITIONAL COMMENTS

There are two types of acrylic available, cast and extruded. Cast turns white or frosted and extruded remains clear when engraved. Use extruded acrylic for paint filled engraving and cast for regular engraving. Cast engraves better without masking. Lightly engrave the surface to frost it with a low power setting such as the first setting listed above. If deep engraving is desired, it is necessary to mask the acrylic with transfer tape to prevent the smoke from damaging the clear surface of the acrylic. However, another problem with deep acrylic engraving is that the intense heat creates a white, crusty, deposit that accumulates along the edges of the area that was just engraved and is impossible to remove

without causing damage. Engraving lightly and without masking seems to be the better all around alternative.

If only cutting acrylic, extruded works better and is less expensive than cast. The cut edges of extruded acrylic will appear to be more highly polished and clearer than cast acrylic when laser cut. When cutting acrylic, it might be necessary to remove both sides of the original masking and re-mask with transfer tape if cutting through the original masking produces flaming. The original masking is coated with wax and will not absorb water. If cutting through very thick acrylic, re-mask both sides with transfer tape and dampen the masking on both sides of the acrylic with water from a spray bottle. Elevate the acrylic off the table at least 1/8 inch, re-focus, then proceed to cut. Elevating the acrylic will allow the beam to completely pass through the material which allows the smoke and heat to escape from underneath. If cutting directly on the engraving table, the trapped heat might cause the bottom edge of the cut to pit and distort. Re-masking and dampening with water will act as a heat sink to pull the laser heat away from the cutting area resulting in less distortion or heat effected zones (HAZ). When dampening, be sure not to leave puddles of water. Puddles of water will reduce cutting depth significantly. For the best results when combining engraving and cutting on the same piece, first engrave lightly and unmasked. Then mask with transfer tape, dampen, elevate, re-focus, and cut as a second step.

Paint filling the engraved area is possible by first masking the acrylic or leave on the original masking then engraving through the masking. Before removing the masking, brush or spray on some acrylic based or water based paint right on to the masking. When the paint is dry, remove the masking and the paint will remain in the recessed area of the engraving. Remember to use extruded acrylic when paint filling and cast acrylic when simply engraving.

ACRYLIC - MIRRORED

TYPE	POWER	SPEED	PPI	PASSES	DEPTH
RASTER ENGRAVING (light)	25	100	500	1	.003"

COMMENTS: Engrave unmasked and on the backside in reverse text. Engraving on the front side of mirrored acrylic will visually produce a double image.

TYPE	POWER	SPEED	PPI	PASSES	DEPTH
RASTER ENGRAVING (deep)	100	100	500	1	.010"

COMMENTS: Masking is not necessary because the acrylic is protected from smoke damage by the mirrored backing.

TYPE	POWER	SPEED	PPI	PASSES	DEPTH
VECTOR ENGRAVING (fast)	5	10	500	1	.005"

COMMENTS: Again, masking is not necessary because the acrylic is protected from smoke damage by the mirrored backing.

TYPE	POWER	SPEED	PPI	PASSES	DEPTH
VECTOR CUTTING	50	1	500	2	.125"

COMMENTS: Make sure both sides are masked. Dampen and elevate at least 1/8" above the engraving table. Two passes make a cleaner cut than one. Cut from the front side of the mirror to prevent heat distortion of the mirrored back surface.

ADDITIONAL COMMENTS

Engraving mirrored acrylic is similar to engraving regular acrylic. The idea is to engrave through the mirrored backing enough to begin to penetrate into the acrylic. Engraving deeply will cause, a crusty

residue to form just like with non-mirrored acrylic. A double image will appear if engraving on the front side of the mirror. It is not necessary to mask the backside when engraving because the mirrored backing shields the acrylic from smoke damage. To cut mirrored acrylic, it might be necessary to remove all original masking, re-mask with transfer tape, and dampen the tape with water from a spray bottle. Next, place the acrylic in the laser with the mirrored surface facing upwards and elevate at least 1/8 inch above the table. The laser beam will not reflect off of the mirrored surface because it is absorbed by the acrylic first. Sometimes cutting the acrylic from the back side will cause the mirrored backing to distort and crack from the intense heat required to cut. If the combination of engraving and cutting is desired, our suggestion is to engrave the backing, unmasked, remove the acrylic, mask both sides with transfer tape, flip the acrylic over, dampen, elevate, re-focus, and cut from the front side. When paint filling the engraved area, make sure to use an acrylic based paint or paint that does not contain acetone or alcohol as these chemicals will crack the acrylic. Water based paints also work very well. Since the mirrored backing serves as a masking, it is not necessary to mask the back side before engraving.

ANODIZED ALUMINUM

TYPE	POWER	SPEED	PPI	PASSES	DEPTH
RASTER ENGRAVING	30	100	500	1	.001"

COMMENTS: The power required is dependent on the thickness of the anodized coating. Do not overpower because the anodized will either be dull in appearance or the engraving lines will be too thick.

TYPE	POWER	SPEED	PPI	PASSES	DEPTH
VECTOR ENGRAVING (fast)	2	1	500	1	.001"

COMMENTS: Different anodized coatings will require higher or lower power settings.

TYPE	POWER	SPEED	PPI	PASSES	DEPTH
VECTOR ENGRAVING (faster)	20	10	500	1	.001"

COMMENTS: Power must be increased if engraving at a faster speed.

BRASS - COATED

TYPE	POWER	SPEED	PPI	PASSES	DEPTH
RASTER ENGRAVING	20	100	1000	1	.002"

COMMENTS: Engrave unmasked. Use a light setting to engrave through the coating. Using 1000 PPI seems to have a cleaner removal of the coating. Some thicker coated brass will require more power. Too much power might discolor the brass and might also cause a loss of resolution on the finer details of the engraving.

TYPE	POWER	SPEED	PPI	PASSES	DEPTH
VECTOR ENGRAVING	15	10	1000	1	.002"

COMMENTS: Engrave unmasked. Use enough power to expose the brass. Too much power will cause thicker engraving lines.

ADDITIONAL COMMENTS

The manufacturing processes for coated brass varies from one vendor to another. Some of the manufacturers do not polish the brass before coating it. Since CO₂ lasers at this power level do not engrave into metals when the coating is removed, the brass underneath will be unaffected and remain tarnished with a dull appearance and will need to be polished with a brass polishing compound. This type of brass is designed for mechanical engravers that actually remove the metal when engraving which gives the brass a shine without polishing. Brass that is produced for the laser engraving industry is polished, then clear coated, and finally coated with paint. When laser engraving this type of material, adjust the power so that the laser beam removes the painted coating but not the clear coating. This will expose the polished, clear coated brass without penetrating all the way down to the metal. Since the brass is already clear coated and polished, it will not require any cleanup after engraving nor will it ever oxidize. If too much laser power is used, the brass the clear coat will be removed and the brass underneath will be exposed to the heat of the laser beam causing instant tarnish. The same goes for enamel coated pens, some are polished and clear coated underneath, and others are tarnished which will require polishing after engraving. If polishing the brass, use a soft, non-abrasive cloth or tissue and good quality brass polish. Be careful not to rub too hard as this will scratch the painted coating. Do not use paper towels either because they will scratch also. Clear coated brass can also be engraved and the engraved area turned black with an oxidizer giving exceptional results. Test clear coated brass from

different vendors as not all of them will work properly. Apply the same parameters and engraving techniques when using coated aluminum.

CORIAN or AVONITE

TYPE	POWER	SPEED	PPI	PASSES	DEPTH
RASTER ENGRAVING	100	100	500	1	.005"

COMMENTS: Mask first before engraving if planning to paint fill.

TYPE	POWER	SPEED	PPI	PASSES	DEPTH
RASTER ENGRAVING (deep)	100	75	500	1	.010"

COMMENTS: Mask first if planning to paint fill.

TYPE	POWER	SPEED	PPI	PASSES	DEPTH
RASTER ENGRAVING (deeper)	100	50	500	1	.015"

COMMENTS: Mask first if planning to paint fill.

TYPE	POWER	SPEED	PPI	PASSES	DEPTH
VECTOR ENGRAVING	50	10	500	1	.010"

COMMENTS: Mask first if planning to paint fill.

ADDITIONAL COMMENTS

Laser engraving this type of material produces spectacular results especially when the engraved area is paint filled. If paint filling, it is a good idea to mask first and then engrave through the masking. In this way, when ready to paint fill, the material is already masked. Spray painting seems to be the easiest. Using a paint brush is acceptable but time consuming. Use the paint sparingly. Excess paint can accumulate on the edges of the engraving which will make mask removal difficult and leave unsightly ridges. Remove the masking after the paint has dried. Engraving this material without paint filling can work but most of the time there is very little contrast which makes the engraved area difficult to see.

CORK

TYPE	POWER	SPEED	PPI	PASSES	DEPTH
RASTER ENGRAVING	50	100	500	1	.010"

COMMENTS: Engraved unmasked.

TYPE	POWER	SPEED	PPI	PASSES	DEPTH
RASTER ENGRAVING (deep)	100	100	500	1	.020"

COMMENTS: Engrave unmasked.

TYPE	POWER	SPEED	PPI	PASSES	DEPTH
VECTOR ENGRAVING	10	10	500	1	.010"

COMMENTS: Engrave unmasked.

TYPE	POWER	SPEED	PPI	PASSES	DEPTH
VECTOR CUTTING	50	1	100	1	.060"

COMMENTS: Unmasked. A low PPI setting is used to prevent flaming.

ADDITIONAL COMMENTS

Cork is not very popular for engraving but it does engrave and cut nicely. Cork is mainly used for making gaskets by vector cutting the gasket patterns.

GLASS

TYPE	POWER	SPEED	PPI	PASSES	DEPTH
RASTER ENGRAVING	50	50	500	1	.000"

COMMENTS: Since glass will not vaporize when laser engraving, it does not require a lot of laser power.

TYPE	POWER	SPEED	PPI	PASSES	DEPTH
VECTOR ENGRAVING	10	10	500	1	.000"

COMMENTS: Again, since glass will not vaporize, it does not require a lot of laser power.

ADDITIONAL COMMENTS

Glass engraving is different from other types of engraving. A CO2 laser cannot engrave into the glass nor can it cut glass. Instead, laser interaction with glass causes the surface of the glass to appear frosted. Sometimes, placing a piece of newspaper on the glass and dampening it with water will improve the appearance of the engraving.

LEATHER

TYPE	POWER	SPEED	PPI	PASSES	DEPTH
RASTER ENGRAVING (light)	20	100	500	1	.003"

COMMENTS: Engrave unmasked.

TYPE	POWER	SPEED	PPI	PASSES	DEPTH
RASTER ENGRAVING (deep)	40	100	500	1	.010"

COMMENTS: Engrave unmasked. Deeper engraving will require masking to prevent smoke damage.

TYPE	POWER	SPEED	PPI	PASSES	DEPTH
VECTOR ENGRAVING	5	10	500	1	.003"

COMMENTS: Engrave unmasked.

TYPE	POWER	SPEED	PPI	PASSES	DEPTH
VECTOR CUTTING	60	1	200	1	.100"

COMMENTS: Cut unmasked. A low PPI setting is used to prevent flaming when cutting.

ADDITIONAL COMMENTS

Leather is a very simple material to engrave and most types of leather engrave very well with the laser system. Simulated leather engraves well also, but the results are not as nice as with the real thing. Engraving lightly will turn the surface of the leather dark brown giving it a high contrast in appearance. Try engraving at a light power setting first. If the result is not deep enough the job can be run again over the same spot. Experiment with different depths of engraving and note the results.

MARBLE

TYPE	POWER	SPEED	PPI	PASSES	DEPTH
RASTER ENGRAVING	100	100	500	1	.003"

COMMENTS: Engrave unmasked. Too much laser power by running too slowly will engrave too deep and discolor.

TYPE	POWER	SPEED	PPI	PASSES	DEPTH
VECTOR ENGRAVING	10	1	500	1	.003"

COMMENTS: Engrave unmasked.

TYPE	POWER	SPEED	PPI	PASSES	DEPTH
VECTOR ENGRAVING (fast)	20	10	500	1	.003"

COMMENTS: Engrave unmasked.

ADDITIONAL COMMENTS

Most marble and polished stones will turn white when engraved. Masking is not necessary and light engraving works out better than heavy and deep engraving. Engraving deeply will cause a highly detailed image to appear washed out. The objective is to engrave deep enough to turn the marble white and provide a good contrast. Too much power can also cause the material to discolor and turn brown as if it were burned. Photographs look great when engraved on marble, especially darker marbles where the whiteness of the engraving really stands out. Avoid using marble that is very textured looking. The texture washes out the details of the engraving. Try to use uniformly colored marble and related stones. Marble can also be paint filled by using a wax based paint. Rub the paint on with a fingertip, let dry and then buff with a soft cloth. The paint will only adhere to the engraved surface and not the surrounding areas.

MAT BOARD

TYPE	POWER	SPEED	PPI	PASSES	DEPTH
RASTER ENGRAVING	30	100	250	1	.005"

COMMENTS: Engrave unmasked. A low PPI setting is used to prevent discoloration.

TYPE	POWER	SPEED	PPI	PASSES	DEPTH
VECTOR ENGRAVING	5	10	250	1	.005"

COMMENTS: Engrave unmasked and at a low PPI setting.

TYPE	POWER	SPEED	PPI	PASSES	DEPTH
VECTOR CUTTING	70	10	200	1	.050"

COMMENTS: Mask on both sides and elevate above the table at least 1/8". Use a lower PPI setting to reduce discoloration of the cutting edge.

ADDITIONAL COMMENTS

Mat board (thick cardboard) is an excellent material to use for architectural modeling and for picture framing. It cuts and engraves very neatly and cleanly. It comes in a variety of shades and colors. Patterns can be engraved on the surface with a power setting for light engraving which just breaks through the very thin top layer and exposes the lighter colored underlying substrate. When engraving, a low **PPI** setting is used to prevent overexposure of the underlying substrate material which causes excessive dark discoloration. Masking is not necessary on the top surface when engraving. When cutting, both sides might need to be masked and the material elevated above the engraving table. This will produce an extremely clean edge on both sides of the material.

MELAMINE - STANDARD ENGRAVING

TYPE	POWER	SPEED	PPI	PASSES	DEPTH
RASTER ENGRAVING	100	100	500	1	.015"

COMMENTS: Engrave unmasked.

TYPE	POWER	SPEED	PPI	PASSES	DEPTH
RASTER ENGRAVING (deep)	100	75	500	1	.020"

COMMENTS: Engrave unmasked.

TYPE	POWER	SPEED	PPI	PASSES	DEPTH
RASTER ENGRAVING (deeper)	100	50	500	1	.030"

COMMENTS: Engrave unmasked.

TYPE	POWER	SPEED	PPI	PASSES	DEPTH
VECTOR ENGRAVING	25	10	500	1	.010"

COMMENTS: Engrave unmasked.

ADDITIONAL COMMENTS

Engraving melamine is very similar to engraving regular wood with the added benefit of a consistent surface finish and uniform base material composition. Unlike regular wood which has grain patterns and density variations, melamine when laser engraved produces a flat and even engraved area. This characteristic gives this material superior engraving and paint filling qualities. Masking can be used if desired but it is just as easy to spray the engraved area with water and wipe down with a chamois cloth to remove the smoke residue. Since the top surface material is consistent in texture and color,

engraving photographs or highly detailed images produces exceptional results. Refer to the next example on engraving photographs and/or ClipArt.

MELAMINE - PHOTO/CLIPART ENGRAVING

TYPE	POWER	SPEED	PPI	PASSES	DEPTH
RASTER ENGRAVING	40	100	500	1	.008"

COMMENTS: Engrave unmasked. Use a **FILL SPACING** of **2** and the **HIGH RESOLUTION** switch **ON**.

TYPE	POWER	SPEED	PPI	PASSES	DEPTH
RASTER ENGRAVING	100	75	500	1	.008"

COMMENTS: Engrave unmasked. Use a **FILL SPACING** of **4** and the **HIGH RESOLUTION** switch **OFF**.

ADDITIONAL COMMENTS

Engraving photographs can be challenging at first but becomes easier once there is an understanding of what to look for and how to achieve the desired results. In an image processing software, scan the image in at 300 DPI. Adjust the brightness and the contrast to brighten the light colors and darken the dark colors. The photo might look better by using a sharpening filter to sharpen up the image slightly. The next step is to select a halftone pattern. Usually, imaging software gives the choice of using different halftone patterns including frequency of lines per inch and pattern angles. Use a line frequency above 20 and below 100. The size of the dots decreases as the line frequency increases. Experiment to see which pattern looks the best. Big dots look good on some materials and small dots look better on others. If it is not possible to assign a halftone pattern in the imaging software, the ULS Windows printer driver will automatically default to a predetermined pattern based on **FILL SPACING**. The driver will automatically assign a 90 lines per inch, diamond shape halftone pattern at an angle of 45 degrees when the **FILL SPACING** is set to **2** and the **HIGH RESOLUTION** switch is **ON**. It will assign a 45 line per inch diamond shape halftone pattern at an angle of 45 degrees when the **FILL SPACING** is set to **4** and the **HIGH RESOLUTION** switch is turned **OFF**. Choosing a fill spacing larger than **4** is not recommended because resolution becomes too coarse. When using the **B/W RASTER** mode switch, which prints all ClipArt or drawings as grayscale bitmaps, use the same parameters and techniques as for engraving photographs.

PLASTIC - ENGRAVERS

TYPE	POWER	SPEED	PPI	PASSES	DEPTH
RASTER ENGRAVING	30	100	500	1	.003"

COMMENTS: Remove original masking and leave unmasked. Use enough power to remove the surface material and expose the underlying substrate.

TYPE	POWER	SPEED	PPI	PASSES	DEPTH
RASTER ENGRAVING (deep)	90	100	500	1	.015"

COMMENTS: On thicker plastics, remove the original masking and leave unmasked. Set the power high enough to assure the full removal of the top surface and to remove some of the substrate material.

TYPE	POWER	SPEED	PPI	PASSES	DEPTH
VECTOR CUTTING	60	1	150	1	.060"

COMMENTS: Remove original masking. Mask with transfer tape on both sides. Dampen both sides with water and elevate off the engraving table. Remember to re-focus. Make 1 to 2 more passes when cutting thicker plastics.

ADDITIONAL COMMENTS

Engravers plastic comes in many different colors, thicknesses, coatings, and surface textures. About 75 % of the available engravers plastic, including ADA signage materials, will engrave and cut well with the laser system. Microsurfaced plastics seem to work the best because there is less surface material to remove to uncover the substrate. Since most plastics have low melting points, a low PPI setting is used when cutting to reduce the possibility of melting. Masking and dampening with water also helps to reduce melting and keeps the plastic clear of smoke residue. Always remove the original clear masking from the plastic because it does not react well with the laser. Since there are so many types of engravers plastics, the only true way to find out if a particular brand and type will work well with the laser is to experiment. Use these power settings as a guideline for experimentation and adjust as

necessary. Be creative when engraving this type of material because amazing results will be produced that cannot be reproduced with a mechanical engraver.

RUBBER STAMPS

TYPE	POWER	SPEED	PPI	PASSES	DEPTH
RASTER ENGRAVING	100	30	500	1	.040"

COMMENTS: Different blends and densities of rubber will engrave to different depths. Test the rubber first to determine the correct power settings.

TYPE	POWER	SPEED	PPI	PASSES	DEPTH
VECTOR CUTTING	40	1	150	1	.040"

COMMENTS: Keep the PPI low to prevent flaming while cutting.

ADDITIONAL COMMENTS

Our rubber stamp option is revolutionizing the rubber stamp industry. With special electronics and a special system driver, it is possible to engrave rubber stamps with a profile and cut out the stamp in one easy step. The machine produces a taper on each character so that the base of the character is wider than the top printing surface giving greater stability when stamping. If trying to engrave stamps without this option, the letters will not have a profile, be very thin and flimsy, and will collapse while stamping them. If you do not have this option and would like to add it to your system, please contact one of our engineers in the sales department for current pricing. All laser systems can be upgraded to have this extraordinary feature.

In the above example, only one pass is necessary to achieve a deeply engraved rubber stamp. When cutting out the rubber stamp, we recommend using a very low PPI setting. This setting spreads the laser pulses far enough apart that they just touch at the edges. The result is a perforated cut that allows the rubber stamp to remain attached to the entire sheet but easily removed by simply tearing it off. The advantage to this is that the possibility of distortion or melting while cutting is virtually eliminated and the entire sheet of rubber stamps can be removed from the machine at one time instead of having to pick them up one by one. Some blends of rubber produce a powdery residue when engraved. Using compressed air and blowing off the residue usually will clean the rubber effectively.

SIGN VINYL - 3 MIL

TYPE	POWER	SPEED	PPI	PASSES	DEPTH
RASTER ENGRAVING	100	75	500	1	.015"

COMMENTS: These parameters are for engraving vinyl on wood. Apply the vinyl to the wood and squeegee out air bubbles. Mask with transfer tape. Engrave deep enough to go through the tape, vinyl, and into the wood. Make a second pass to go deeper. Engraving at a slower speed might cause the vinyl to melt.

TYPE	POWER	SPEED	PPI	PASSES	DEPTH
VECTOR CUTTING	5	10	250	1	.003"

COMMENTS: Unmasked, cuts through vinyl and not the backing. Thicker vinyl requires more power and thinner ones require less. Adjust as necessary.

ADDITIONAL COMMENTS

Sign vinyl comes in a wide variety of colors, patterns, thickness, finishes, and reflectivity. There are a few methods for using sign vinyl with the laser system. One method is to vector cut (unmasked) through the vinyl but not through the backing. This technique provides results equivalent to a vinyl cutter machine. Once the vinyl has been cut, remove the excess vinyl, apply transfer tape and use a squeegee to remove trapped air bubbles. The transfer tape can then be lifted off and the vinyl lettering or objects that were vector cut will stick to the transfer tape and maintain their correct spacing with respect to each other. Now apply the tape to the desired surface and squeegee, peel off the transfer tape, and the lettering will remain adhered to the surface. The other method is to apply a piece of vinyl to the desired surface (unmasked) and adjust the laser power so as to cut through the vinyl without engraving into the material below. Another popular example of the use of vinyl is to cover the entire surface of a wooden plaque with vinyl, use a squeegee to remove all air bubbles, and then mask the entire surface with transfer tape to protect the vinyl from smoke damage due to the wood engraving involved. In the graphics software, color the background one of the eight driver colors and place white filled text on top of the colored background. Since the laser system does not engrave white filled objects, the background will be engraved and the lettering will be untouched. Then peel off the excess vinyl and transfer tape to reveal the final product. The lettering will be raised and vinyl coated!

WOOD - FINISHED WALNUT

TYPE	POWER	SPEED	PPI	PASSES	DEPTH
RASTER ENGRAVING	100	100	500	1	.020"

COMMENTS: Engrave unmasked. If masking, reduce the speed setting to 80% to get the same depth.

TYPE	POWER	SPEED	PPI	PASSES	DEPTH
RASTER ENGRAVING	100	75	500	1	.030"

COMMENTS: Engrave unmasked. If masking, reduce speed to 55% to get the same depth. To engrave deeper it is recommended to make more passes instead of reducing speed.

TYPE	POWER	SPEED	PPI	PASSES	DEPTH
VECTOR ENGRAVING	25	10	500	1	.030"

COMMENTS: Engrave unmasked.

TYPE	POWER	SPEED	PPI	PASSES	DEPTH
VECTOR CUTTING	50	1	500	1	.125"

COMMENTS: Elevate at least 1/8" off of the engraving table. Lightly dampen bottom side with water. Both surfaces can also be masked and dampened with water. Elevating will let heat and smoke escape from underneath and prevent burning.

ADDITIONAL COMMENTS

When engraving wood with a laser, a brown, maple syrup like residue will deposit on the surface of the wood. This is normal and impossible to eliminate by **POWER**, **SPEED**, or **PPI** changes. More residue will be present when engraving deeper and/or slower. This residue washes off with water and a

sponge. We recommend using a kitchen sponge with a nylon string mesh wrapped around it. Dampen the sponge and wipe off the residue. A damp chamois cloth works well also. Do not use paper towels or a regular sponge because these materials will get lodged in the engraved area when wiping and are extremely difficult to remove. A method to avoid cleanup is to mask the wood with transfer tape and peel off the tape after engraving. If desired, after engraving and before peeling off the tape, spray paint can be applied to color fill the engraved areas. After the paint dries, peel of the tape. If an intricate drawing has been engraved and there are many small pieces of tape to remove, it may be easier to flood the masking, after engraving, with water. This will loosen the tape and it can be easily removed by rubbing it off by hand. In the vector cutting example, the wood was elevated from the table to let smoke and heat escape from underneath. If elevating the wood, mask and/or dampen the bottom side of the wood very lightly and the water acts as a heat sink to prevent the underside from flaming and charring. Elevating the wood also helps to determine whether the laser has passed completely through since the cut pieces will fall through to the table when cutting is finished. If raising the wood, set up the drawing so that the inner pieces of the drawing are cut first, otherwise pieces may fall through at the wrong time.

Not all wood finishes are created equal. When ordering wood from a supplier, be sure to specify that it is being used for laser engraving. Some finishes cannot handle the heat from the laser and will bubble, blister, and possibly turn white. For engraving softer woods such as pine or balsa, reduce the power settings to acquire the best depth. Engraving too deep on soft woods will reduce quality. Every type of wood will engrave differently. Experiment with different types of wood and note the results. It is better to engrave woods that are finished. If engraving unfinished wood and it is not masked with transfer tape, the smoke residue tends to embed in the wood and is impossible to remove without sanding. To prevent this, mask all unfinished wood with transfer tape.

WOOD INLAYS - VENEERS

Create a drawing with no outlines, only filled areas. Engrave the filled areas almost as deep as the thickness of the veneer (usually about .003 inches or less). With some water and a nylon brush, remove all residue from the engraved area. When cutting veneers make sure they are lying absolutely flat. In the drawing, give the objects an outline of .001 inches and remove the fill. Adjust the power so that there is just enough power to cut completely through the veneer. Overpowering the cut will cause too much material removal and the fit will not be snug. Some software programs allow outline offsetting to compensate for the thickness of the beam. This is called contouring and is optimal if planning to do this type of work. Usually, a contour to the outside of the vector line of .006 inches provides a tight fit. Remember, if using more power to cut through the veneer, compensate for the thicker width of the laser cut by contouring a little further to the outside.

A good veneer to use are those with an adhesive backing. Once cut, place the veneer into its proper place on the engraved wood block and with a clothes iron, iron the veneer into the engraved wood. This melts the glue and causes the veneer to stick to the engraved area. The veneer can now be sanded flush with the surface and a finish coat applied.

SECTION 5 - BASIC MAINTENANCE

5.1 GENERAL CLEANING OF THE SYSTEM

A visual inspection of the machine should be done at least once a day. If dirt or debris is present a general cleaning should be performed. The frequency of cleaning will depend entirely on the type of material being cut or engraved. Dirt allowed to build up in any parts of the motion system will cause uneven engraving or loss of position as well as damage to optics and premature failure of the motion system components. Use good judgment and keep in mind that a clean machine is the best performing machine.

NOTE: The rails of the system should be wiped down with a dry lint free cloth at least once a day regardless of whether a general cleaning is required. This will guarantee longer bearing life.

CAUTION: Never lubricate the motion system.



WARNING

Always turn the laser engraving system off and unplug it before performing any cleaning procedures.

General cleaning procedure:

1. Ensure that the system is turned off and unplugged and open the top door.
2. Thoroughly remove all loose dirt and debris from inside the machine.
3. With the engraving table fully in the up position, clean table surface with glass cleaner and paper towels.
4. Move engraving table down to bottom position and clean the vertical slide which moves the plate up and down with glass cleaner and paper towel.
5. Clean all of the rails of the motion system, using a cotton swab and alcohol. Pay particularly close attention to the grooves that the bearings move in since any debris left to build up in these grooves will cause the bearings to wear and the motion system to become rough.
6. After the rails are cleaned, use a clean swab and alcohol to clean all of the bearings by holding the swab against each bearing and moving the motion system by hand to roll the bearings against the swab. There are seven bearings in the system, three on the small optics holder assembly and four on the front of the motion system arm. The four front bearings can be cleaned most easily through the front door.

7. To clean the exhaust, remove the exhaust panel from the inside left wall of the system by removing the four screws on the front of the panel. When replacing the panel, make sure to press it tightly into place while tightening the screw so that the panel makes a good seal with the system.
8. Check the intake air filter on the outside right wall of the system. If it is dirty, clean it by submerging it in a mild soap solution, rinsing it clean and allowing it to air dry. If the intake filter is allowed to become too dirty it can restrict air flow making the exhaust less effective.
9. Clean the laser cooling fan grills and the laser fan cover.
10. Clean the top window with tissue and Windex. Do **NOT** use paper towels because they will scratch acrylic.

5.2 HOW TO CLEAN THE OPTICS

The optical elements in the system are provided with a durable, multilayer coating that will withstand repeated cleanings if cleaned properly. A visual inspection of the mirrors and lens should be performed at least once a day. If a haze or debris is present on the optical surfaces, they should be cleaned. As a general rule, if the machine itself is dirty the optical elements are probably dirty too.

Follow these instructions to clean the optics:

CLEANING THE LENS

1. Remove the 4-40 thumb screw from the side of the lens holder located on the movable optics carriage. Hold the lens holder while removing the screw so the holder and lens do not drop.
2. Inspect the lens while still in the holder. If the lens does not look too dirty or most of the dirt seems to be on the bottom surface of the lens, leave the lens in the holder and clean only the bottom surface using the cleaning instructions below. If the lens is extremely dirty, it will need to be disassembled.
3. To disassemble the lens holder assembly, (lens holder housing, threaded insert, two lens spacers, one lens) unscrew the threaded insert while keeping the housing flat so the spacers and lens do not fall out.

4. Sit down in front of a table and remove the lens from the lens holder by holder it in your left hand and a clean sheet of lens tissue flat in your right hand. Carefully turn the lens holder upside down onto a piece of the lens tissue which came with the system so that lens and spacers drop out onto the tissue.
5. Inspect lens spacers and clean them if necessary with a swab and lens cleaner.
6. Hold the lens by its edges using lens tissue, and with a stream of lens cleaning solution from the small plastic wash bottle that came with the system, flush both surfaces of the lens.

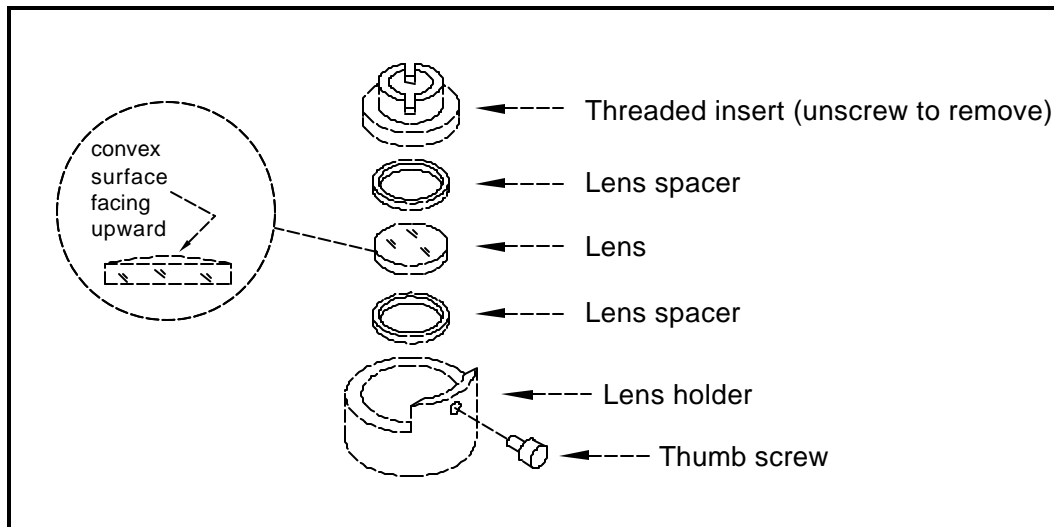

7. Apply some of the lens cleaning solution to one surface of the lens. Let it sit for approximately one minute and then gently wipe the surface using several sheets of lens tissue soaked with lens cleaning solution.
8. Dry that side of the lens using dry lens tissue and repeat the process to clean the other side of the lens.

NOTE: Never reuse the lens tissue twice. Dust build-up on the tissue may scratch the surface of the lens.

9. Inspect the lens. If it is still dirty, repeat the cleaning procedure until it is clean.
10. Place one of the spacers into the lens holder and gently insert the lens into the lens holder ensuring that the curved (convex) side of lens is facing upward away from the spacer. Place the remaining spacer on top of the lens and screw the threaded insert snugly into place.

CAUTION: Over-tightening the threaded insert can cause the lens to break.

11. Carefully slide the lens holder assembly back onto the optics carriage on the rail.

12. Replace the 4-40 thumb screw and gently tighten it.

CLEANING THE MIRRORS

There are two mirrors inside the processing area of the system that need to be cleaned. Follow the procedure below to clean both of mirrors:

1. While holding the mirror bracket, remove the 4-40 thumb screw and lift mirror and holder away from the mirror mount. Be careful not to slide the mirror across the mount since they can scratch easily.
2. Use a stream of lens cleaning solution from the small plastic wash bottle to flush the surface of the mirror.

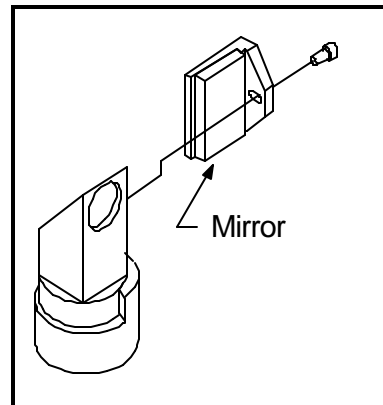
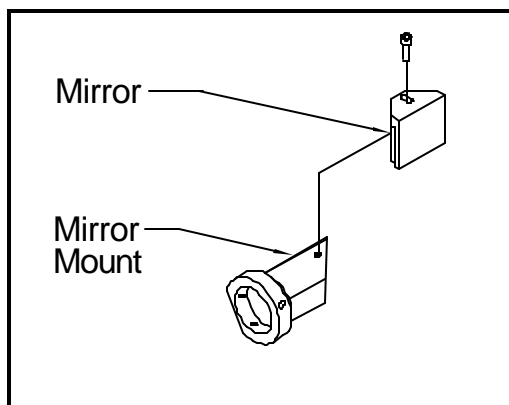

3. Apply lens cleaning solution to the mirror and let it sit for approximately one minute.
4. Use a folded piece of lens tissue soaked in lens cleaning solution and gently wipe it across the mirror once. Use new lens tissue soaked in lens cleaning solution and repeat wiping with each new tissue across the mirror once until the mirror is clean and then dry it with a dry lens tissue. Never use a tissue twice as dust build-up on the tissue may scratch the mirror's surface.
5. Inspect the mirror and repeat the procedure if necessary until the mirror is clean.
6. Replace the mirror on the mirror mount by setting the mirror bracket straight down on to the mount. Make sure that the mirror is sitting flat against the holder otherwise a beam misalignment can occur. Replace the 4-40 thumb screw and tighten it securely.

CAUTION: Sliding the mirror on the holder can scratch it.

CLEANING THE WINDOW

A small window is located inside the machine underneath the protective overhang for the motion system arm. Slide the motion system out from underneath the overhang to access the window. This window seals the rest of the system from the processing area and the outside of the window will need to be cleaned regularly. Follow these steps to clean the window:

1. Use a stream of lens cleaning solution from the small plastic wash bottle to flush the surface of the window.
2. Soak a lens tissue with lens cleaning solution and then gently wipe the surface of the window. Use more lens tissue soaked in lens cleaning solution if necessary.
3. Finally, dry the window using a dry lens tissue.
4. Inspect the window and repeat the procedure if necessary until the window is clean.

APPENDIX A - WARRANTY

APPENDIX B - LASER SYSTEM SPECIFICATIONS

<u>Model Number</u>	ULS-25
Maximum Engraving Area	17" x 11.5"
Maximum Engraving Speed	16.5"/second
Laser Source	25 Watt CO ₂
Laser Beam Diameter	
- Standard Optics	0.007"
- High Resolution Optics (Optional)	0.003"
Repeatability	+/- 0.002"
Interfaces	Parallel = Centronics Serial = RS-232C
Buffer Memory Size	4MB (upgradeable to 16MB)
System Dimensions	37" x 30" x 38"
System Weight	170 lb.
Safety Classification	Class I
Focal Plane (Z axis) Adjustment	6.25"

Facility Requirements

Electrical Power:	Single phase, 120 VAC, 50/60 Hz, 10 Amp
Exhaust:	235 CFM minimum at 6 inches of static pressure
Cooling:	Air cooled ambient temperature between 60 and 78 degrees Fahrenheit

Specifications are subject to change without notice.

APPENDIX D - LASER.INI MODIFICATIONS

ADVANCED PROCEDURES

To speed up the download process to the laser system, a file modification can be made.

If the computer being used has 8 or more megabytes of RAM, open up the LASER.INI file in the windows directory using a text editor. Scroll down to the bottom of the file and type in the following line exactly how it reads:

```
BandKBytes=2000
```

This line will allow the computer to use more of its memory for printing.

Save this file and restart Windows for the change to take effect.

APPENDIX E - SOFTWARE ANOMALIES

In order for certain software to work properly with a Universal Laser System, some modifications might have to be made. If using the following software, be sure to follow these instructions. If having any difficulty making these adjustments, please contact our technical support.

CORELDRAW

If experiencing problems printing text in CorelDraw!, especially mirrored text, make this modification to the files listed below:

COREL 3.0

Find the CORELDRW.INI file usually located in the c:\windows\coreldrw\draw\ subdirectory. Open this file up in a text editor such as NOTEPAD, which comes with Windows. Scroll down about 55 lines to find the line that reads:

```
FontRasterizer=1
```

and change it to read:

```
FontRasterizer=0
```

Save this file and restart CorelDraw! for the changes to take effect.

COREL 4.0

Find the CORELAPP.INI file usually located in the c:\windows\corel40\config\ subdirectory. Open this file up in a text editor such as NOTEPAD, which comes with Windows. Scroll down about 63 lines to find the line that reads:

```
FontRasterizer=1
```

and change it to read:

```
FontRasterizer=0
```

Save this file and restart CorelDraw! for the changes to take effect.

COREL 5.0

Find the CORELAPP.INI file usually located in the c:\windows\corel50\config\ subdirectory. Open this file up in a text editor such as NOTEPAD, which comes with Windows. Scroll down about 64 lines to find the line that reads:

```
FontRasterizer=1
```

and change it to read:

```
FontRasterizer=0
```

Save this file and restart CorelDraw! for the changes to take effect.

Printing photographs through CorelDraw!

Version release 3.0B and version 5.0 do not currently support our drivers halftone pattern generator. What this means is that if trying to print a grayscale photograph through these versions, it will come out as a solid black and white engraving with no halftone generation. There is no current solution available for this problem. Our suggestion is to use version 3.0A, and any of the 4.0 releases until this problem can be resolved or if it can be resolved. Please contact our technical support if there are any questions.